

Guide

Controlling risks associated with Electroplating

Disclaimer

This publication contains information regarding work health and safety. It includes some of your obligations under the *Work Health and Safety (National Uniform Legislation) Act* – the WHS Act – that NT WorkSafe administers. The information provided is a guide only and must be read in conjunction with the appropriate legislation to ensure you understand and comply with your legal obligations.

Acknowledgement

This guide is based on material produced by Safe Work Australia at www.swa.gov.au



Creative Commons

All material presented in this publication is provided under a Creative Commons Attribution 3.0 Australia licence.

For the avoidance of doubt, this means this licence only applies to material as set out in this document.

The details of the relevant licence conditions are available on the Creative Commons website as is the full legal code for the CC BY 3.0 AU licence.

Version: 1.1

Publish date: September 2018

Contents

Introduction	4
What is electroplating?	4
Who has duties associated with electroplating?	5
How to manage health and safety risks	6
Chemical hazards and control measures	8
Chemical Health Hazards	8
Acids	9
Arsine Gas	9
Chromic Acid	9
Cyanide	10
Dusts	10
Nitric Acid	10
Solvents	10
Chemical Safety Hazards – Fire and Explosion	11
Control Measures	11
Isolation of Hazardous Chemicals	11
Storage and handling	12
Spills	12
Keeping hazardous chemicals stable	12
Monitoring airborne contaminants and using exposure standards	13
Health monitoring	13
Fire and ignition sources	15
Emergency plans and fire fighting equipment	15
First Aid	15
Safety signs	16
Personal Protective Equipment	16
Workplace Facilities	17
Other Hazards and control measures	17
Electrical Hazards	17
Plant Hazards	18
Noise	19
Hazardous Manual Tasks	19
Appendix A – Definitions	20
Appendix B – Cyanide Poisoning	21

Introduction

People working in the electroplating industry may face risks from hazardous chemicals, metals, wet work, live electrical currents and heavy machinery.

This Guide primarily addresses the hazards involved with storage and handling of hazardous chemicals used in electroplating, however, it also contains some guidance regarding electrical, plant, noise and manual handling hazards. It applies to all workplaces where electroplating is carried out, and where relevant, can be applied to other processes such as anodising, hot-dip galvanising, electroless plating and general metal finishing.

What is electroplating?

Electroplating is the coating of a metal object with another metal, using an electrical current passed through a chemical solution. This system is made up of:

- a cathode – the material to be plated
- an anode – the plating metal or inert conductor
- an electrolytic solution – a salt solution used to immerse the anode and cathode containing metal ions to be coated
- an electrical current – provided by an electrical source such as a battery or other power unit.

Figure 1 shows a simplified diagram of the electroplating circuit.

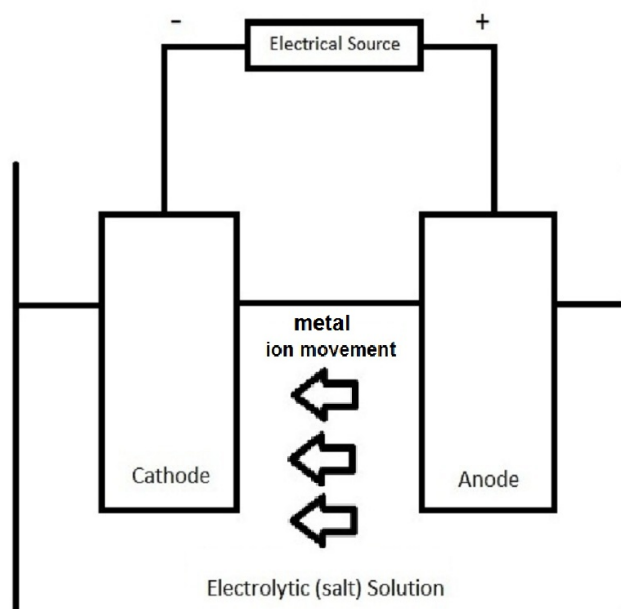

Figure 1: Electroplating system

Objects commonly plated include machine and automotive parts, fixing devices, jewellery and electrical components.

The electroplating process involves the use of hazardous chemicals from pre-treatment (solvent degreasing, alkali cleaning and acid dipping), during plating, to the final buffing, grinding and polishing of the product. Electroplating uses metals including chromium, nickel, cadmium, zinc, copper, silver and gold, dissolvable salts incorporating cyanide and sulphate, acids and alkaline solutions. A list of common metals and solutions used in electroplating is shown in Table 1.

Table 1: Common electroplating metals and solutions

Metal	Solution
Chromium	Chromic acid (chromium trioxide) with sulphuric acid
Nickel	Nickel sulphate with boric acid and nickel chloride
Cadmium	Cadmium oxide with sodium cyanide and sodium hydroxide Cadmium cyanide in alkaline solution
Zinc	Zinc sulphate with boric acid Zinc oxide with sodium cyanide and sodium hydroxide Zinc cyanide in alkaline solution Zinc chloride with hydrochloric acid
Copper	Copper sulphate in weak sulphuric acid Copper sulphate with sodium cyanide in alkaline solution Copper cyanide with sodium cyanide in alkaline solution
Silver	Silver cyanide in alkaline solution Potassium silver cyanide in alkaline solution

Further definitions of terms used in this Guide are provided in Appendix A.

Who has duties associated with electroplating?

A person conducting a business or undertaking (PCBU) has the primary duty under the WHS Act to ensure, so far as is reasonably practicable, that workers and other persons are not exposed to health and safety risks arising from the business or undertaking. This duty includes ensuring, so far as is reasonably practicable, the safe use, handling and storage of plant and substances.

- **Designers, manufacturers, importers and suppliers of plant, substances or structures** must ensure, so far as is reasonably practicable, that the plant, substance or structure is without risks to the health and safety of persons who, at a workplace, use the plant, substance or structure for a purpose for which it was designed or manufactured.

There are also specific duties under the WHS Regulations for workplace chemicals that include:

- the manufacturer or importer of a substance must determine whether the substance is a hazardous chemical, and if it is determined to be hazardous chemical, to prepare a safety data sheet and correctly label
- the supplier of a hazardous chemical must provide the current safety data sheet for the chemical when it is supplied to a person at a workplace

Officers, for example, company directors, have a duty to exercise due diligence to ensure that the business or undertaking complies with the WHS Act and Regulations. This includes taking reasonable steps to ensure that the business or undertaking has and uses appropriate resources and processes to eliminate or minimise risks.

Workers have a duty to take reasonable care for their own health and safety and must not adversely affect the health and safety of other persons. Workers must comply with any reasonable instruction and cooperate with any reasonable policy or procedure relating to health and safety at the workplace.

How to manage health and safety risks

The WHS Regulations require persons conducting a business or undertaking to *manage risks* including those associated with plant, hazardous manual tasks, noise, hazardous chemicals and electrical risks.

Regulations 32-38: In order to manage risk under the WHS Regulations, a duty holder must:

- identify reasonably foreseeable hazards that could give rise to the risk
- eliminate the risk so far as is reasonably practicable
- if it is not reasonably practicable to eliminate the risk – minimise the risk so far as is reasonably practicable by implementing control measures in accordance with the hierarchy of risk control
- maintain the implemented control measure so that it remains effective
- review, and if necessary revise all risk control measures so as to maintain, so far as is reasonably practicable, a work environment that is without risks to health and safety

This Guide provides information on how to manage the risks associated with electroplating, particularly in relation to hazardous chemicals. When managing these risks, regard must be had to the following factors:

- the hazardous properties of the hazardous chemical
- any potentially hazardous reaction (chemical or physical) between the hazardous chemical and another substance or mixture, including a substance that may be generated by the reaction
- the nature of the work to be carried out with the hazardous chemical
- any structure, plant or system of work that:
 - is used in the use, handling, generation or storage of the hazardous chemical
 - could interact with the hazardous chemical at the workplace.

The hierarchy of control

There are a number of ways to control the risks associated with electroplating. Some control measures are more effective than others. Control measures can be ranked from the highest level of protection and reliability to the lowest. This ranking is known as the *hierarchy of control*. You must always aim to eliminate a hazard and associated risk first. If this is not reasonably practicable, the risk must be minimised by using one or more of the following approaches:

- substitution
- isolation
- implementing engineering controls.

If a risk then remains, it must be minimised by implementing administrative controls, so far as is reasonably practicable. Any remaining risk must be minimised with suitable personal protective equipment (PPE).

Examples of application of the hierarchy of controls for electroplating are provided in Table 2. A combination of control measures may be needed to effectively eliminate or minimise risk.

Table 2: Hierarchy of controls

Hierarchy Steps	Examples
Elimination	<ul style="list-style-type: none"> ■ using another process
Substitution	<ul style="list-style-type: none"> ■ using trivalent chromium instead of hexavalent chromium ■ selecting quiet machinery
Isolation	<ul style="list-style-type: none"> ■ separation of incompatible chemicals ■ automated work processes ■ providing partial and total enclosures on plating tanks ■ using partitions around work areas
Engineering controls	<ul style="list-style-type: none"> ■ local exhaust ventilation ■ machine guarding ■ using bath additives or surfactants in plating tanks ■ use of bubble dispersers on the liquid surface
Administrative controls	<ul style="list-style-type: none"> ■ shift rotations ■ restricted access to work areas ■ work processes that minimise exposure ■ equipment, floor, bench and fixture maintenance ■ workplace education
Personal protective equipment	<ul style="list-style-type: none"> ■ chemical goggles ■ gloves ■ aprons ■ respirators

Guidance on the general risk management process is available in the *Code of Practice: How to Manage Work Health and Safety Risks*.

Information, instruction and training

Section 19: A PCBU is to provide relevant information, instruction, training and supervision necessary to protect all persons from risks to their health and safety arising from work carried out.

Regulation 39: The WHS Regulations require that a PCBU must ensure that information, training and instruction provided to a worker is suitable and adequate having regard to:

- the nature of the work carried out by the worker
- the nature of the risks associated with the work at the time of the information, training and instruction, and
- the control measures implemented.

Workers must be made aware of the need to carry out their work in such a way as to minimise contamination, and the importance of proper use and care of all control measures implemented to protect health and safety.

The training provided must be readily understandable by any person to whom it is provided.

In workplaces where cyanide is being used, stored or handled, workers should be trained to recognise the symptoms of cyanide poisoning and to apply relevant first aid procedures.

Chemical hazards and control measures

Chemical Health Hazards

Workers at electroplating workplaces may be exposed to hazardous chemicals in the form of fumes, vapours, mists, metal dusts, electrolytic solutions, solvents, heavy metals and toxic wastes.

Exposure to chemical hazards may cause short and/or long term health problems including skin and eye irritation, burns, asthma/breathing problems, nerve disorders, and in some cases, cancer.

Adverse health effects due to exposure to hazardous chemicals are dependent on the type and amount of contact, the duration of exposure and the route of entry into the body.

Exposure to hazardous chemicals in an electroplating workplace can occur:

- when containers leak or spill during transport, storage, decanting or disposal
- if fumes or gases build up during storage or use in confined or inadequately ventilated areas
- during the electroplating process (splashing when placing or removing items in the tank, from metal or acid aerosols as a result from excessive bubbling or fuming in electrolytic solutions)
- if extraction systems removing corrosive mists or toxic gases fail, are inadequate or improperly designed or installed

- if there is inadequate housekeeping (drips and spills, incorrect disposal of wastes, poor clean up procedures causing incidental contact with contaminated surfaces) during cleaning, maintenance or repair of tanks
- if toxic gases are released due to accidental mixing of incompatible chemicals
- if personal protective equipment is inadequate
- through skin contact with contaminated personal protective equipment.

Electroplating processes such as solvent degreasing may lead to dermatitis and skin infections, as well as vapour exposure which can lead to anaesthetic and toxic effects. Alkali cleaning involves the use of sodium carbonate which when mixed with other alkalis may form a mist irritating to skin, eyes and respiratory mucosa. Buffing and polishing hazards are related to the generation of dusts.

Information regarding the hazards of chemicals, recommended controls, instructions on use, storage and disposal, and personal protective equipment can be found on labels and safety data sheets (SDS).

Acids

The process of acid dipping includes the use of hydrochloric, hydrofluoric, sulphuric and nitric acids which are all corrosive to the skin and eyes. Acid mists may be evolved from high concentrations of acid, air or tank content agitation or elevated tank temperatures. Acid mists irritate the skin, eye, nose and throat, and may result in chest pain, cough and shortness of breath.

Hydrofluoric acid is highly toxic and corrosive through skin and eye contact. High levels of exposure may cause organ failure and death. Calcium gluconate gel should be kept readily available for treatment of burns.

Arsine Gas

Arsine gas is formed when an acid comes into contact with most solutions containing arsenic ions and a source of nascent hydrogen, often provided by the presence of other metals in acid. Arsenic may be present as an impurity in metal or in commercial grades of sulphuric and hydrochloric acids. Arsenic is occasionally used in very dilute solutions as an aid in electroplating of rhodium and noble metals in order to improve adhesion, hardness and as a brightener to the finish of those metals.

Arsenic poisoning can be acute due to its haemolytic activity, or chronic due to its carcinogenic potential. Symptoms include headache, dizziness, stomach pains, vomiting, delirium, seizures and coma.

Chromic Acid

Chromic acid is a strong irritant and corrosive. Exposure usually arises as the result of:

- splashes
- as a mist of chromic acid coated bubbles of hydrogen
- as chromic acid contaminated dust.

Chromic acid affects the skin, nasal and bronchial mucosal linings. On the skin, chromic acid can cause chronic ulcers known as 'chrome holes'. In the nasal cavity, chrome ulceration affects the nasal septum and can cause perforation. When inhaled as a mist or contaminated dust, chromic acid can cause nasal irritation, rhinitis and bronchitis. If splashed in the eyes, chromic acid can cause severe injury including conjunctival inflammation and corneal injury.

Chromic acid contains soluble hexavalent chromium which is toxic and carcinogenic.

Cyanide

Cyanide solutions contain cyanide ions and are corrosive to skin and eyes and highly toxic if swallowed. If the pH of a cyanide plating bath falls below approximately pH10, the air above the bath may contain high levels of hydrogen cyanide gas. This will also occur when cyanide ions comes into contact with an acid.

Hydrogen cyanide gas smells of bitter almonds and as a chemical asphyxiant is one of the most rapidly acting of all known poisons. Not all people are able to recognise the odour and reliance on the sense of smell should not be used as a warning signal. Symptoms of cyanide poisoning include weakness, confusion, shortness of breath, headache, dizziness, seizures and coma.

Cyanide salts may be present in solid form, such as sodium cyanide or potassium cyanide. Cyanide solids are highly toxic if swallowed.

Dusts

Grinding or polishing machines are used for the grinding, polishing and buffing of metal objects by means of an abrasive wheel, scratch-brush wheel, grinding and finishing belt or other similar equipment. When used in conjunction with abrasive polishes, these generate fine dusts and should have an efficient local ventilation system or a dust extraction system fitted.

Long term exposure to such dusts can lead to pneumoconiosis with symptoms including inflammatory reactions within the lungs, coughing, chest tightness and shortness of breath.

Nitric Acid

In addition to its corrosive effects, nitric acid requires particular care because of the potential for liberation of nitrogen oxides. Water-soluble nitrogen oxides can cause respiratory tract irritation and can lead to chemical pneumonia. Nitrogen oxides with low water solubility can penetrate deep into the lungs and may result in delayed health effects such as lung edema (fluid accumulation in the lungs).

Solvents

Most solvents used in electroplating pre-treatment processes are organic chlorine, alcohol or petroleum based chemicals which have powerful properties to dissolve organic solids. They are often mixtures of several chemicals and can be particularly hazardous. Commonly used hazardous solvents in electroplating include acetone and trichloroethylene.

Solvents can be inhaled, ingested or absorbed through the skin. They can cause short term adverse health effects such as dermatitis including drying, cracking, reddening or blistering of the skin, headaches and drowsiness, poor co-ordination, and nausea. Exposure to high concentrations of solvent vapour can lead to unconsciousness and death.

Long term health effects from solvent exposure include effects on the brain and nervous system, the skin, liver, bone-marrow, kidneys, fertility and the foetus, and some solvents are carcinogenic.

Some solvents have synergistic effects. This means that they will have greater health effects in combination with other hazards. For example when using some organic solvents, adverse health effects will be greater if you smoke cigarettes or drink alcohol soon after handling.

Chemical Safety Hazards – Fire and Explosion

The safety hazards of a chemical include its flammability and reactivity. Flammability is the tendency of a chemical to burn. Solvents are common flammable chemicals in an electroplating workplace. Reactivity is the potential of the material to explode or react violently with air, water or other substances upon contact. Some metal dusts produced during buffing and grinding may create an explosion hazard if there is an ignition source.

Control Measures

To ensure the health and safety of workers involved with the use, storage and handling of hazardous chemicals, the substance, mixture or article must:

- be correctly classified
- be correctly packaged
- be correctly labelled
- have a current and safety data sheet.

Detailed information on the management of risks from hazardous chemicals is available in the Code of Practice: *Managing Risks of Hazardous Chemicals in the Workplace*.

Isolation of Hazardous Chemicals

Use, handling and storage of hazardous chemicals requires the elimination of the risk of physical or chemical reactions. For example, ensuring any form of cyanide does not come into any contact with an acid, keeping concentrated nitric acid separate from organics such as solvents and oils, or keeping oxidising agents isolated from combustibles. Isolation can be achieved, for example, by the use of separate storage cupboards or by undertaking plating involving cyanide in a separate work area from plating involving acids.

Articles treated in acid baths should be thoroughly rinsed with water before being placed in plating tanks.

Cyanides need special attention and must be clearly labelled, and stored in a secure, dry place separated completely from acids. If possible, enclosed systems should be utilised when using cyanide.

Storage and handling

Hazardous chemicals must be stored appropriately. This involves using the correct container, isolation of incompatible chemicals, the use of flammable or specialised chemical cupboards, and the correct labelling of containers. Workers must be trained in the proper storage and handling of the chemicals involved in electroplating processes to minimise risk. Safety data sheets must be provided for the workers involved as they assist to communicate the proper use, handling, storage and disposal of hazardous chemicals, as well as providing detailed safety precautions including recommended personal protective equipment.

Further information on toxic or corrosive substances is available in the following Australian Standards:

- AS 3780: The storage and handling of corrosive substances
- AS/NZS 4452: The storage and handling of toxic substances

Spills

When handling, using or storing hazardous chemicals a spill containment system must be provided to ensure that any risks from spills are minimised, that the spill is contained within the workplace, and the spill containment system separates incompatible chemicals for example cyanide and acids. This may include:

- installing a floor that is impervious to the chemicals being used
- pumping chemicals into plating tanks instead of pouring manually from containers
- a raised floor fitted with collection bunds (separated bunds for incompatible chemicals)
- providing spill kits with suitable absorbent materials.

Keeping hazardous chemicals stable

Regulation 356: A PCBU must ensure, so far as is reasonably practicable, that hazardous chemicals do not become unstable, decompose or change so as to create a hazard different to the hazard originally created by the hazardous chemical or significantly increase the risk associated with any hazard in relation to the hazardous chemical.

Where practical, stabilisation systems should be automated, for example, automatic addition of stabilisers to plating tanks. Stability may be achieved by:

- maintaining the proportions of constituents as described on the safety data sheet or as advised by the manufacturer
- temperature regulation
- pH regulation
- surface tension regulation.

Vapour degreasing tanks should be positioned in an area free from any contact with high temperature sources to prevent the production of toxic decomposition products and maintain chemical stability. Tanks should have sufficient heat and vapour condensation controls, and materials being cleaned should be handled in a manner that minimises the risk of exposure to vapours, for example the use of overhead lifting devices.

Monitoring airborne contaminants and using exposure standards

Regulation 49: A PCBU must ensure that no person at the workplace is exposed to a substance or mixture in an airborne concentration that exceeds the relevant exposure standard for the substance or mixture.

Hazardous chemicals such as acids, alkalis and hydrogen cyanide, and metals such as chromium, cadmium, zinc, copper and silver used in electroplating have exposure standards that must be adhered to. Monitoring of workplace contaminant levels may need to be carried out if:

- there is an uncertainty whether or not the exposure standard has been or may be exceeded, or
- it is necessary to determine whether there is a risk to health.

These records of air monitoring must be kept for a minimum of 30 years, and must be available to workers who are exposed. More information regarding exposure standards can be found in the Safe Work Australia publication *Guidance for the Interpretation of the Workplace Exposure Standards for Airborne Contaminants*.

Electroplating may cause the formation of hazardous fumes, mists or gases. Controls may include the use of:

- local exhaust ventilation
- surfactants or physical surface modifiers
- temperature control
- personal respiratory devices.

Local exhaust ventilation for plating tanks may include a rim extraction system. Extraction should be designed according to the risk of exposure and the hazards of the chemicals being used. Small tanks may require an extraction slot along one side only, while larger tanks may require a 'push-pull' extraction system that moves air across the surface of the tank and away from the worker.

Local exhaust ventilation should also be fitted to grinding and buffing machines to remove dust.

Electroplating workers should be trained about the risks of airborne contaminants and their controls. Electroplating workplaces have the potential to have asphyxiants such as hydrogen in the workers' breathing zone. Controls may include the use of ventilation systems and oxygen or hydrogen monitoring devices.

Health monitoring

Regulation 368: Health monitoring must be provided for workers where exposure to a hazardous chemical contained within Schedule 14 of the WHS Regulations presents a significant risk to the worker's health.

Schedule 14 is a list of hazardous chemicals requiring health monitoring and their associated types of health monitoring. These chemicals include chromium, cadmium and arsenic which are commonly encountered during electroplating.

Health monitoring must also be provided for workers using hazardous chemicals not listed in Schedule 14 where there is a significant risk to the workers' health from exposure to the hazardous chemical and there are valid techniques to detect adverse health effects or a valid biological monitoring procedure is available.

Some examples of common hazardous chemicals used in electroplating that may pose a significant risk to workers' health and types of health monitoring can be found in Table 3. For further information, see the guidance on health monitoring for exposure to hazardous chemicals.

Table 3: Common hazardous chemicals used in electroplating and their related health effects and recommended tests for health monitoring

Hazardous Substance	Health Risk	Health Monitoring
Chromium* compounds	Ulceration of nose/skin Skin sensitisation Occupational asthma Occupational cancer	Skin inspection Respiratory testing Blood tests
Nickel	Dermatitis Occupational cancer Occupational asthma	Skin inspection Respiratory testing Blood tests
Acids/Alkalis Degreasers/Cleaners	Dermatitis Burns and Ulceration Eye/nose/throat irritation	Skin inspection General health check
Trichloroethylene	Dermatitis Eye/skin irritation Occupational cancer	Skin inspection General health check
Cyanide solutions/sludge	Poisoning Dermatitis Headaches/Nausea/Dizziness	Skin inspection General health check
Cadmium* containing powders/solutions	Poisoning Respiratory effects Anaemia/Liver dysfunction	Respiratory testing Blood tests
Cadmium* oxide	Occupational cancer	Blood tests Respiratory testing
Platinum salts	Occupational asthma	Respiratory testing
Oxides of nitrogen	Respiratory effects	Respiratory testing
Copper compounds	Dermatitis Eye/skin irritation Gastrointestinal effects	Skin inspection General health check Blood tests
Arsenic*	Haemolytic action on blood	Peripheral nervous system testing Skin inspection Urinary inorganic arsenic

* Schedule 14 hazardous chemicals

Fire and ignition sources

Electroplating baths can generate highly flammable hydrogen bubbles which may be released into the air. Hydrogen gas is potentially explosive between 4% and 75% by volume in air.

Regulation 355: A PCBU at a workplace must, if there is a possibility of fire or explosion in a hazardous area being caused by an ignition source being introduced into the area, ensure the ignition source is not introduced into the area (from outside or within the space).

Emergency plans and fire fighting equipment

Regulation 43: A PCBU must prepare an effective emergency plan for the workplace.

Regulation 359: A PCBU at a workplace must ensure that fire protection and fire fighting equipment:

- is designed and built for the types of hazardous chemicals at the workplace in quantities in which they are used, handled, generated or stored at the workplace and the conditions under which they are used, handled, generated or stored
- is compatible with fire fighting equipment used by primary emergency services organisations
- is properly installed, tested and maintained
- has its latest testing date recorded and test results kept until the next test is conducted.

All workplaces must have appropriate and maintained fire fighting equipment.

Hazardous chemicals may require specialised fire fighting equipment, for example certain forms of cyanide require powder fire extinguishers, and cyanide exposure can occur if smoke from a fire is inhaled.

Details about special emergency procedures and safety equipment can be found on the chemical's SDS.

First Aid

First Aid equipment must be made available to workers, be maintained and a provision must be made to have trained personnel available to administer first aid if required.

First aid equipment should include deluge showers and eye wash stations for workers handling toxic or corrosive chemicals. In an electroplating workplace special attention should be given to the risks of cyanide poisoning (see Appendix B), and chemical burns.

Specialised safety equipment should be considered, for instance a cyanide antidote poisoning kit or calcium gluconate gel for hydrofluoric acid burns.

For further information, refer to the *First Aid in the Workplace* Code of Practice.

Safety signs

Safety signs may be used to warn of a particular hazard or state the responsibilities of a certain person. A safety sign must be located next to the hazard and be clearly visible to any person approaching the hazard. For example a safety sign for a chemical mixture containing cyanide or arsenic should be placed near a storage cupboard and include the name of the first aid officer.

Further information on the design and use of signs is available in *AS 1319: Safety signs for the occupational environment*.

Electroplating workplaces that use large amounts of hazardous chemicals may be required to display placards if prescribed threshold quantities are exceeded.

For more information on placards and manifest quantities, see Schedule 11 of the WHS Regulations.

Personal Protective Equipment

Regulation 44: If personal protective equipment (PPE) is to be used at the workplace, the PCBU must ensure that the equipment is:

- selected to minimise risk to health and safety
- suitable for the nature of the work and any hazard associated with the work
- a suitable size and fit and reasonably comfortable for the person wearing it
- maintained, repaired or replaced so it continues to minimise the risk
- used or worn by the worker, so far as is reasonably practicable.

Regulation 46: A worker must, so far as reasonably able, wear the PPE in accordance with any information, training or reasonable instruction.

In most circumstances, PPE should not be relied on to control risk. It should be used only as a last resort when all other reasonably practicable control measures have been used and the risk has not been eliminated, or as interim protection until higher level controls are implemented. There may also be situations when the use of other controls is not practicable.

For electroplating PPE may include:

- eye protection
- gloves
- face splash protection
- waterproof apron
- waterproof footwear
- respirator with suitable filters.

Further information on the selection and use of personal protective equipment is available in the following Australian Standards:

- AS/NZS 1715 Selection, use and maintenance of respiratory protective devices
- AS/NZS 1716 Respiratory protective devices
- AS/NZS 1337 Personal eye protection (Series)
- AS/NZS 2161 Occupational protective gloves (Series)
- AS/NZS 2210 Occupational protective footwear (Series)

All equipment must be maintained in good working order and be clean and hygienic. Workers must be trained in the proper use, fitting and maintenance of protective equipment.

Workplace Facilities

An electroplating workplace should provide a clean hand washing station and an area for the changing of contaminated clothing to ensure hazardous chemicals are not spread through the workplace or out into the community. A clean eating area separate from the work area should be provided.

Further information is available in the Code of Practice: *Managing the Work Environment and Facilities*.

Other Hazards and control measures

Electrical Hazards

Electroplating involves a combination of conductive solutions and live electrical currents. Common hazards in electroplating workplaces include exposed live conductors, damaged insulation, broken sockets, corrosion of system parts, and heaters not earthed. A PCBU must manage electrical risks at the workplace.

This may include:

- providing safe and suitable electrical equipment for example not using leads and tools in damp or wet conditions unless they are specially designed for those conditions
- providing enough socket outlets—overloading socket outlets by using adaptors can cause fires
- ensuring power circuits are protected by the appropriate rated fuse or circuit breaker to prevent overloading
- arranging electrical leads so they will not be damaged
- the installation of residual current devices (RCDs)
- the regular inspection and testing of electrical equipment.

For further information on managing electrical risks, see the Code of Practice: *Managing Electrical Risks in the Workplace*.

Plant Hazards

Plant refers to machinery, tools, appliances and equipment. An electroplating workplace may involve a range of plant including:

- forklifts
- overhead travelling cranes
- hoists
- portable electrical tools
- grinding, buffing or polishing machines
- air receivers
- compressors.

Regulation 203: A person with management or control of plant at a workplace must manage risks to health and safety associated with the plant.

A person with management or control of plant at a workplace must also:

- so far as is reasonably practicable, prevent unauthorised alterations to or interference with the plant
- take all reasonable steps to ensure the plant is only used for the purpose for which it is designed, unless a competent person has assessed that the proposed use does not increase the risk to health and safety, and
- ensure all safety features, warning devices, guarding, operational controls, emergency stops are used in accordance with instructions and information provided.

Plant used in environments where the atmosphere is acidic is at an increased risk of corrosion damage.

Regular inspection and maintenance should be conducted, especially for lifting equipment such as cranes, hoists, chains and hooks.

Electroplating workplaces may use cooling towers to control the temperature of plating tank solutions or rectifiers. Cooling towers are at risk of colonisation of hazardous bacteria such as *Legionella*. Cooling towers should be regularly inspected, cleaned and treated with an appropriate microbicide. For more information, see *AS/NZS 3666 Air-handling and water systems of buildings*.

Further information on plant risks is available in the Code of Practice: *Managing Risks of Plant in the Workplace*.

Noise

Some areas of an electroplating workplace may generate hazardous noise (noise that exceeds the exposure standard for noise), for example a buffing and grinding area. Hazardous noise can destroy the ability to hear clearly and can also make hearing sounds necessary for working safely more difficult, for instance instructions or warning signals.

Regulation 57: A PCBU must manage risks to health and safety relating to hearing loss associated with noise including ensuring that the noise a worker is exposed to at the workplace does not exceed the exposure standard for noise.

Noise can be reduced and controlled by:

- obtaining noise information from the manufacturer and selecting quieter plant
- ensuring plant is well maintained
- if noise levels are still hazardous after higher order controls are implemented, providing personal hearing protectors.

Further information is available in the Code of Practice: *Managing Noise and Preventing Hearing Loss at Work*.

Hazardous Manual Tasks

Regulation 60: A PCBU must manage risks to health and safety relating to a musculoskeletal disorder associated with a hazardous manual task.

Electroplating workplaces may involve manual tasks including pushing, pulling, lifting or carrying heavy chemical containers, plant and items for plating. Buffing and grinding on fixed machines may involve repetitive movement. These activities may result in strain injuries. Controls may include:

- using smaller containers
- use of trolleys or cranes
- safe work procedures
- providing appropriate training.

Further information is available in the Code of Practice: *Hazardous Manual Tasks*.

Appendix A – Definitions

Acid dipping means a pre-treatment process involving the use of mineral acids, most commonly hydrochloric and sulphuric acids.

Alkali cleaning means a pre-treatment process involving electrolytic cleaning with alkalis, most commonly sodium carbonate or sodium hydroxide.

Anode means the positive electrode in an electroplating or anodising solution.

Anodising means a process that involves the anodic oxidation of metals (commonly aluminium, titanium, zinc, magnesium, niobium and tantalum).

Cathode means the negative electrode in an electroplating or anodising solution.

Electrode means the conductor through which electricity enters or leaves an electrolyte, gas, vacuum or other medium.

Electroless plating means the deposition of a metal from a solution of its salts involving reduction and oxidation reactions.

Electrolyte means a solution able to conduct electrical current.

Pre-treatment process means a process to ensure that grease, dirt, oxides, other solutions and scales are removed from the surface of the metal before coating.

Solvent degreasing means a pre-treatment process that involves the use of chlorinated hydrocarbons (usually trichloroethylene or perchloroethylene) in either heated liquid or hot vapour form (vapour degreasing).

Tank means the vessel containing electrodes and electrolytic solution.

Appendix B – Cyanide Poisoning

With suitable controls in operation, cyanide poisoning is rare. However, all workers and people within the vicinity of cyanide processes should be well educated in identification of symptoms, safe working and first aid procedures.

Unless there is firm evidence to demonstrate cyanide exposure has occurred, a patient is most likely to be suffering from something else.

Cyanide antidotes such as hydroxocobalamin, sodium thiosulphate and dicobalt edetate must only be administered by trained emergency services officers or medical professionals.

Mild and early cyanide poisoning

The onset of symptoms resulting from cyanide exposure is very rapid.

Symptoms of mild or early cyanide poisoning include:

- nausea
- headache
- giddiness
- sense of suffocation
- agitation
- irritation of nose, mouth and/or throat
- vomiting (if route of exposure is ingestion).

These symptoms are similar to signs exhibited by people with the fear of poisoning and patients suffering from carbon monoxide poisoning, and should be assessed accordingly.

Severe cyanide poisoning

Symptoms of severe cyanide poisoning may be characterised by:

- gasping for breath
- loss of consciousness
- seizures
- cardiac arrest.

Without prompt treatment, death can result.

Rescue

It is essential that rescuers of cyanide affected people are trained in emergency procedures and use of personal protective equipment.

No attempt at rescue should be performed until an appropriate hazard assessment of the exposure site is made and appropriate personnel are in place and personal protective equipment is available. DO NOT enter a potentially hazardous area to rescue a victim unless using positive pressure self-contained breathing apparatus as cyanide gas may be inhaled from the surrounding atmosphere.

Special care needs to be taken when handling a patient, as skin and clothing may be contaminated. Absorption through the skin is a significant source of exposure to cyanide. Gloves and goggles should be worn and all clothing (including that of the patient), should be carefully removed and placed in a sealed receptacle for decontamination or disposal.

First Aid

Application of first aid to a patient who has cyanide poisoning must be prompt. Only a trained rescuer or first aid officer wearing appropriate personal protective equipment including personal respirator, gloves and goggles should undertake treatment of a patient. Always consult the Safety Data Sheet for specific First Aid advice.

If cyanide poisoning has occurred immediately:

- dial 000 for an ambulance
- assess area for risks to rescuer
- take all protective precautions including double gloving and respiratory devices;
- remove patient from source of contamination and into fresh air
- remove all contaminated clothing and wash contaminated skin, mouth and lips with copious amounts of fresh water
- if the patient is conscious or unconscious but breathing, administer 100% oxygen, and continue oxygen until medical assistance arrives
- if the victim is fully conscious and has swallowed cyanide induce vomiting before administering 100% oxygen
- if victim is unconscious check for signs of life and commence external CPR if required
- if not breathing wipe away any foreign material from the mouth and employ the use of a resuscitation bag and mask, avoid mouth to mouth resuscitation and DO NOT inhale victim's expired breath
- arrange for urgent transfer of the patient, accompanied with a cyanide antidote kit and appropriate SDS, to professional medical care.

Professional care will generally include the support of breathing and circulation, oxygen administration, blood sampling and treatment with a cyanide antidote.

Cyanide poisoning emergency kit

Where there is an identified risk of exposure to cyanide, special items should be kept in an accessible and convenient position. These items should be maintained appropriately and, if possible, located adjacent to an oxygen source and personal breathing equipment for contaminated atmospheres. Trained staff should be available during the hours of cyanide use. Items for a cyanide emergency kit include:

- an oxygen resuscitator and a source of oxygen
- a minimum of four pairs of gloves
- safety eyewear
- plastic bags labelled with 'contaminated with cyanide'
- a clearly marked cyanide antidote box containing:
 - an approved airway
 - elasticised tourniquet
 - disposable indwelling intravenous cannulae
 - 20 mL sterile disposable syringes and needles
 - fluoride heparinised blood sample tubes
 - skin prep swabs, dressings and adhesive tape
 - ampoules of antidote including the prescribing information outlining side effects and precautions
- a copy of the appropriate SDS for the cyanide compound or mixture.

NT WorkSafe

Work Health and Safety

Toll-free 1800 019 115

Email ntworksafe@nt.gov.au

Fax 08 8999 5141

Workers Rehabilitation and Compensation

Toll-free 1800 250 713