

Guide to working with crystalline silica and crystalline silica containing products

Disclaimer

This guide has been adapted from the Working with crystalline silica and crystalline silica containing products guidance material produced by Safe Work Australia.

This guide includes references to the legal requirements under the Work Health and Safety (National Uniform Legislation) Act 2011 (WHS ACT) and Work Health and Safety (National Uniform Legislation) Regulations 2011 (WHS Regulations). These are included for convenience only and should not be relied on in place of the full text of the WHS Act or WHS Regulations.

Creative Commons

With the exception of the NT WorkSafe and the Northern Territory Government logo, this copyright work is licensed under a Creative Commons Attribution 4.0 International licence. To view a copy of this licence, visit creativecommons.org/licenses. In essence, you are free to copy, communicate and adapt the work for non-commercial purposes, as long as you attribute the work to Safe Work Australia and abide by the other licence terms.

Contact information

Safe Work Australia | <mailto:info@swa.gov.au> | www.swa.gov.au

Document title	Guide to working with crystalline silica and crystalline silica containing products
Contact details	NT WorkSafe
Approved by	Peggy Cheong
Date approved	26 June 2024
Document review	1 September 2024

Version	Date	Author	Changes made
1.0	26 June 2024	Peter Chan	Adapted national guide for NT use.

Acronyms	Full form
CSS	Crystalline silica substances
HRCT	High-resolution computed tomography
HSR	Health and safety representative
IP	Ingress protection
LEV	Local exhaust ventilation
PCBU	Person conducting a business or undertaking
RCS	Respirable crystalline silica
PMF	Progressive massive fibrosis
RPE	Respiratory protective equipment
SDS	Safety data sheet
SWMS	Safe work method statement
WHS	Work Health and Safety

Contents

1. Introduction	5
1.1 Who should use this guide?	5
1.2 What are crystalline silica containing products?	5
1.3 What is respirable crystalline silica?	6
1.4 Health effects of RCS	7
1.5 Silicosis	8
1.6 How to use this guide	8
2. Who has health and safety duties?	9
2.1 Persons conducting a business or undertaking (PCBU)	9
2.2 Officers	10
2.3 Principal contractors	10
2.4 Designers, manufacturers, importers, suppliers and those who install, construct or commission plant or structures	11
2.5 Workers	12
2.6 Other persons in the workplace	12
2.7 WHS laws in your state or territory	Error! Bookmark not defined.
3. Managing health and safety risks	13
3.1 Consulting with workers	14
3.2 The risk management process	15
3.3 Identify the hazards	15
3.4 Assess the risks	17
3.5 Maintain and review control measures	26
3.6 Information, training, instruction and supervision	27
3.7 Safe Work Method Statements	27
4. Ventilation and wet cutting	28
5. Personal Protective Equipment	31
Respiratory protective equipment (RPE)	32
6. Monitoring	35
6.1 Air monitoring	35
6.2 Health monitoring	37
7. More information	Error! Bookmark not defined.

1. Introduction

1.1 Who should use this guide?

You should use this guide if you are a person conducting a business or undertaking (PCBU) who has workers (including yourself) that work with materials or products containing crystalline silica, including any permitted work with engineered stone.

From 1 July 2024, a PCBU must not carry out, or direct or allow a worker to carry out, work that involves the manufacture, supply, processing or installation of engineered stone benchtops, panels and slabs.

Engineered stone is defined as an artificial product that contains 1% or more crystalline silica (as weight/weight concentration) that is created by combining materials such as natural stone, water, resins or pigments, and becomes hardened.

For further information on how this applies in your state or territory visit [Safe Work Australia](#).

This guide explains what you must do to keep workers safe from the risks of respirable crystalline silica (RCS).

Your responsibilities as a PCBU will change from 1 September 2024 when new regulations for crystalline silica substances (CSS) containing at least 1% crystalline silica (including engineered stone) come into effect.

Following the new regulations, this guidance will be updated to reflect these additional changes.

1.2 What are crystalline silica containing products?

Crystalline silica containing products covered in this guide include:

- natural stone products such as marble or granite benchtops
- engineered stone products
- sintered stone
- porcelain products
- asphalt
- cement, mortar and grout
- concrete, concrete blocks and fibre cement products
- bricks, and
- pavers and tiles including roof tiles.

From 1 July 2024, work with engineered stone benchtops, panels and slabs is prohibited except under certain circumstances. For more information on the prohibition of engineered stone, permitted work with legacy engineered stone or the process for applying for an exemption from the prohibition you should read the Engineered stone prohibition – Guidance for PCBUs.

This guide will help you, as a PCBU to understand the risks from RCS and make decisions about protecting your workers from exposure to RCS when working with crystalline silica containing products. As well as general information about controlling the risks of working with RCS, it also provides more detailed information to help you control the risks of working with products that may contain high levels of crystalline silica and pose a significant risk to the health of your workers.

1.3 What is respirable crystalline silica?

Crystalline silica is the crystalline form of silicon dioxide, a naturally occurring mineral that forms a major component of most rocks. It is found in natural stones like granite and sandstone and is used to create manufactured products like tiles.

Crystalline silica is defined in the WHS Regulations as crystalline polymorphs of silica, including quartz, cristobalite, tridymite, and tripoli.

Dust is often generated or present when undertaking activities with products or materials that contain crystalline silica, such as:

- during manufacturing and construction
- when mining, quarrying or tunnelling
- in waste from processing products containing silica, and
- in sand-based products.

This dust contains crystalline silica in a range of particle sizes, from very small (less than 10 micrometres [μm] in diameter) to larger particles that can be seen with the naked eye. Crystalline silica particles that are less than 10 μm in diameter (Figure 1) are known as RCS as, when breathed in, they can travel deep into the lungs.

Figure 1. Dust particle sizes (Source: Mining and Quarrying Occupational Health and Safety Committee).

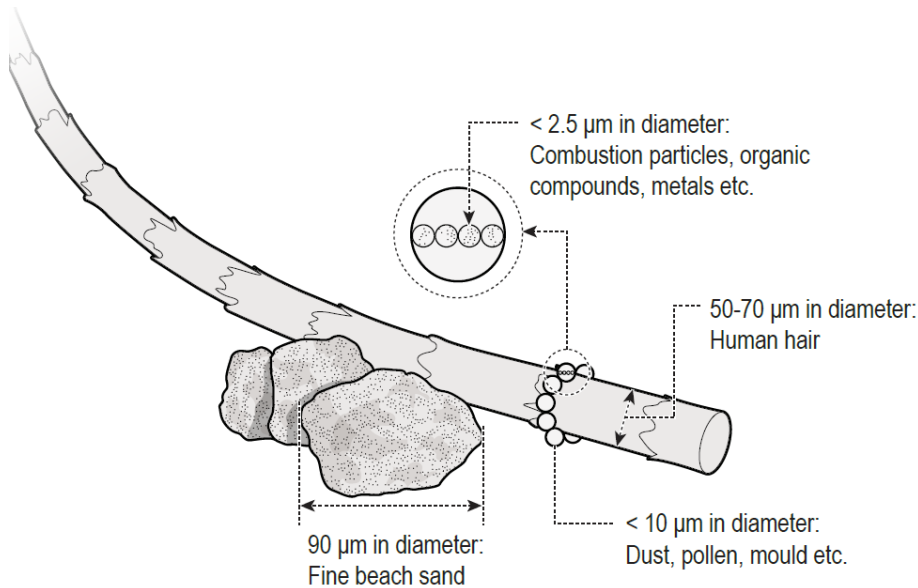

Workers fabricating, processing, installing, maintaining, demolishing, or removing crystalline silica containing products or materials without appropriate control measures in place may be exposed to high levels of RCS (for example through dust or mist clouds). Workers can also be exposed to RCS from poor housekeeping methods that disturb accumulated dust, including dry sweeping, using compressed air or high-pressure water cleaners and general-purpose vacuum cleaners not designed for use with hazardous dusts.

1.4 Health effects of RCS

Crystalline silica containing products or materials in solid form do not cause silicosis and other silica-related diseases; it is the RCS that is generated from processing these materials that has the potential to cause harm when it is breathed in. While there is no known safe level of crystalline silica when a CSS is processed, the higher the crystalline silica content of the material being processed, the greater the risk of exposure to RCS.

RCS is a significant health hazard for workers. RCS is invisible under normal lighting or with the naked eye and stay airborne for long periods of time.

When airborne, workers can breathe RCS deep into their lungs where they can lead to a range of respiratory diseases, including:

- Silicosis
- progressive massive fibrosis
- chronic obstructive pulmonary disease
- chronic bronchitis, and
- lung cancer.

RCS also increases the risk of developing chronic kidney disease, autoimmune disorders (such as scleroderma and systemic lupus erythematosus) and other adverse health effects, including an increased risk of activating latent tuberculosis, eye irritation and eye damage.

1.5 Silicosis

Silicosis is a serious, irreversible lung disease that causes permanent disability and can be fatal. When RCS comes into prolonged contact with the lung tissue, it causes inflammation and scarring and reduces the lungs' ability to take in oxygen. Silicosis may continue to progress even after a worker is removed from exposure to RCS. As the disease progresses, a worker may experience shortness of breath, a severe cough and general weakness. There are three types of silicosis based on the type of exposure and the effects on the lungs (Table 1).

Table 1: Types of silicosis.

Silicosis type	Exposure type	Respiratory effects of exposure
Acute	Can develop after short-term and very high levels of RCS (for example less than one year, and after a few weeks).	Causes severe inflammation and protein accumulation in the lung.
Accelerated	Results from short term exposure to large amounts of RCS (1 to 10 years of exposure).	Causes inflammation, protein accumulation and scarring in the lung (fibrotic nodules).
Chronic	Results from long term exposure (over 10 years of exposure) to low levels of RCS.	Causes scarring of the lung and shortness of breath.

Damage to the lungs and symptoms of disease (such as shortness of breath, severe cough and general weakness) may not appear for many years following exposure to RCS. Workers may not show any symptoms, even at the point of initial diagnosis. There is no cure for silicosis.

However, silicosis and other silica-related diseases are preventable by using effective controls throughout the lifecycle of the product to eliminate or minimise the generation of and exposure to RCS in the workplace.

1.6 How to use this guide

This guide is intended to supplement other information produced by Safe Work Australia to assist you to meet your duties and obligations under WHS laws. You should also read the following:

- Code of Practice: How to manage work health and safety risks, and
- Code of Practice: Construction work.

This guide includes references to the legal requirements under the WHS Act and WHS Regulations. These are included for convenience only and should not be relied on in place of the full text of the WHS Act or WHS Regulations.

In this guide, the word 'must' indicates a legal requirement that must be complied with. The word 'should' indicates a recommended course of action.

2. Who has health and safety duties?

Duty holders with a role in managing the risks of RCS when working with crystalline silica containing products or materials include:

- PCBUs
- Officers
- designers, manufacturers, importers, suppliers
- workers, and
- other persons in the workplace.

A person can have more than one duty and more than one person can have the same duty at the same time.

2.1 Persons conducting a business or undertaking (PCBU)

WHS Act section 19

Primary duty of care

PCBU's have the primary duty of care for the health and safety of their workers and others at the workplace.

A PCBU can be a:

- Company
- unincorporated body or association
- sole trader, or
- self-employed person.

Individuals who are in a partnership that is conducting a business or undertaking will individually and collectively be a PCBU.

A PCBU must ensure, so far as is reasonably practicable, the health and safety of workers at work and ensure that the health and safety of other people is not put at risk from the work carried out by the business or undertaking.

This duty requires the person to manage risks by eliminating health and safety risks so far as reasonably practicable, and if it is not reasonably practicable to eliminate the risks, by minimising those risks so far as is reasonably practicable.

A PCBU also has more specific obligations, which are set out in the WHS Regulations.

2.2 Officers

WHS Act section 27

Duties of officers

An officer (for example a company director) must exercise due diligence to ensure the PCBU complies with the WHS Act and WHS Regulations. This includes taking reasonable steps to ensure the PCBU has and uses appropriate resources and processes to eliminate or minimise risks of working with crystalline silica containing products or materials. This includes:

- identifying the hazard of RCS
- controlling the risk of exposure to RCS
- conducting air monitoring, and
- providing health monitoring for workers.

2.3 Principal contractors

WHS Regulations 308-315

Duties of principal contractors

Projects involving construction work that costs \$500,000 or more are classified as 'construction projects' under the WHS laws. Each construction project has a 'principal contractor'. A principal contractor is also a PCBU. The principal contractor for a construction project is:

- the PCBU that commissions a construction project
- if the PCBU that commissions the project engages another PCBU to be the principal contractor and authorises that second PCBU to have management or control of the workplace and to discharge the duties of the principal contractor, the second PCBU, or
- if the owner of residential premises is an individual who directly or indirectly engaged a PCBU to undertake a construction project in relation to the premises, the PCBU so engaged if the PCBU has management or control of the workplace.

A construction project only has one principal contractor at any specific time.

In addition to the primary duties imposed on a principal contractor as a PCBU, the principal contractor has duties relating to WHS management plans, ensuring general compliance, and managing specific risks.

2.4 Designers, manufacturers, importers, suppliers and those who install, construct or commission plant or structures

WHS Act section 22

Duties of persons conducting businesses or undertakings that design plant, substances or structures

WHS Act section 23

Duties of persons conducting businesses or undertakings that manufacture plant, substances or structures

WHS Act section 24

Duties of persons conducting businesses or undertakings that import plant, substances or structures

WHS Act section 25

Duties of persons conducting businesses or undertakings that supply plant, substances or structures

WHS Act section 26

Duty of persons conducting businesses or undertakings that install, construct or commission plant or structures

A designer, manufacturer, importer or supplier of crystalline silica containing products must ensure, so far as is reasonably practicable, that the crystalline silica containing products they design, manufacture, import, supply or install is without risk to health and safety. This includes undertaking necessary testing and providing adequate information about the crystalline silica containing products.

This information can be provided in the form of a label, product information sheet or a safety data sheet (SDS). Important information that must be provided includes:

- the amount of crystalline silica in the product
- the hazardous properties and risks to health of RCS, and
- the health and safety precautions that must be taken when fabricating, installing, maintaining or removing crystalline silica containing products.

Suppliers of equipment (such as hand-held water-fed power tools or respiratory protective equipment (RPE)) should take all reasonable steps to ensure appropriate information about the safe use of the equipment is available.

Manufacturers do not have a duty to provide safety data sheets (SDS) for solid products that contain crystalline silica, such as brick or tiles. However, it is good practice to make them available.

A PCBU who installs, constructs or commissions structures must also ensure, so far as is reasonably practicable, all workplace activity relating to the plant or structure including its decommissioning or dismantling is without risks to health or safety. A structure is defined as anything that is constructed, whether fixed or moveable, temporary or permanent, and includes buildings, masts, towers, framework, pipelines, transport infrastructure and underground works (shafts or tunnels).

2.5 Workers

WHS Act section 28

Duties of workers

Workers have a duty to take reasonable care for their own health and safety, and to take reasonable care to not adversely affect the health and safety of other persons.

Workers must also:

- comply as far as they are reasonably able with any reasonable WHS instructions given by the PCBU, such as participating in health monitoring and wearing relevant personal protective equipment (PPE), and
- co-operate with any reasonable policy or procedure relating to WHS at the workplace that has been notified to them.

The PCBU must make workers aware of the hazards associated with the use of crystalline silica containing products or materials, including the process for reporting safety incidents.

If a worker refuses to participate in health monitoring or refuses to use PPE as they have been trained and instructed, a PCBU may take action to meet its duties under the WHS laws. This could include removing the worker from the source of exposure to RCS.

2.6 Other persons in the workplace

WHS Act section 29

Duties of other persons at the workplace

Other persons at the workplace, like visitors, must take reasonable care for their own health and safety and must take care not to adversely affect other people's health and safety. They must comply, so far as they are reasonably able, with reasonable instructions given by the PCBU to allow that person to comply with the WHS Act. For example, if a marble benchtop is being installed at a customer's home by a PCBU, that home becomes a workplace. The homeowner and other people who enter the home while it is a workplace are other persons for the purposes of the WHS Act.

Further information on work health and safety duties is in the Code of Practice: How to manage work health and safety risks.

3. Managing health and safety risks

As a PCBU, you must manage the health and safety risks associated with crystalline silica containing products or materials in the workplace.

You will need to implement a combination of different control measures to eliminate or minimise exposure to RCS at your workplace. This includes when working with naturally occurring crystalline silica (for example in quarrying or tunnelling) or working with crystalline silica containing products. The use of higher order controls such as isolation or engineering controls (such as wet dust suppression and local exhaust ventilation) are critical to minimising worker exposure to RCS.

If you rely solely on one control measure, there may be a significant risk to your worker’s health, and you may be breaching WHS laws. It has been shown that solely relying on PPE may not adequately protect your workers from exposure to RCS.

This guide is only intended to provide guidance about how you can control the risks of RCS. It does not cover every hazard that may be present at your workplace. You must be careful to make sure that when you are controlling the risks of exposure to RCS that you are not introducing other hazards or not fulfilling your WHS duties to control other hazards.

You can manage risks of exposure to RCS by selecting and implementing measures using the hierarchy of controls (Figure 2).

Figure 2. The hierarchy of control measures

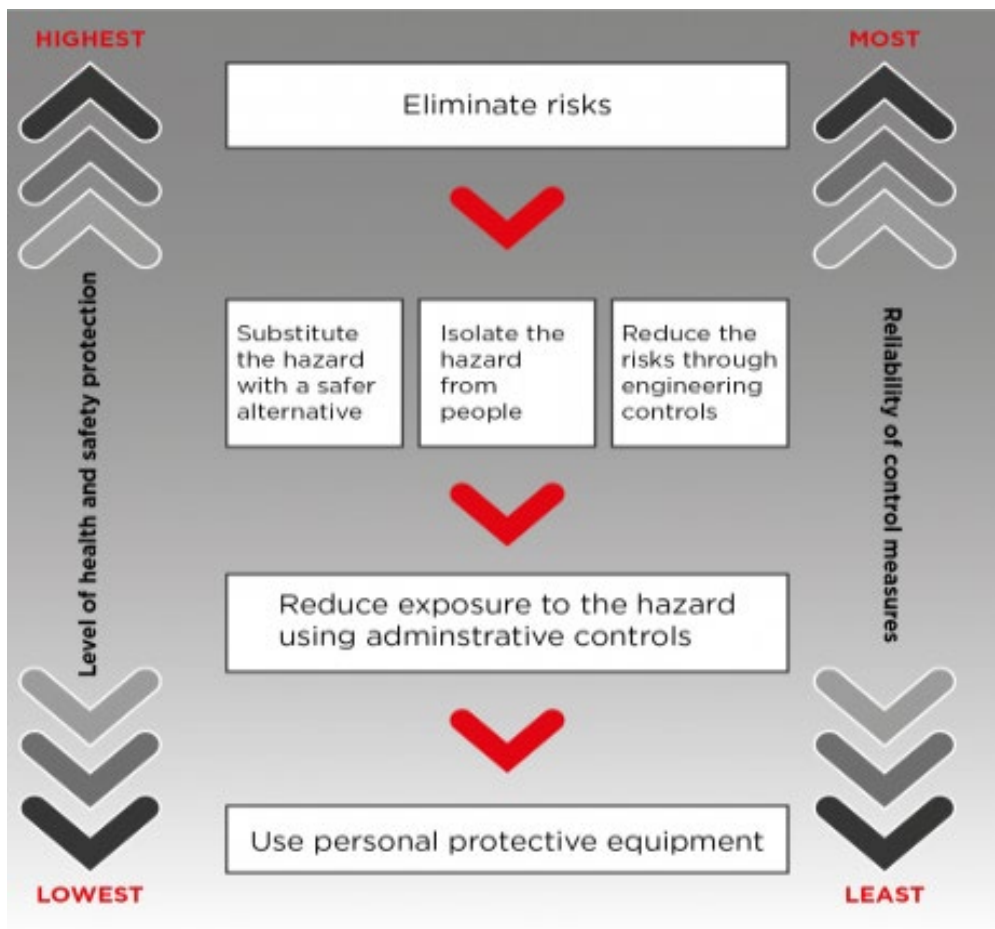

3.1 Consulting with workers

WHS Act section 47

Duty to consult workers

WHS Act section 48

Nature of consultation

You must consult, so far as is reasonably practicable, with your workers and their elected health and safety representatives (if any) about health and safety at your workplace.

Workers must be consulted on health and safety matters, including (but not limited to):

- identifying hazards and risks associated with the use of crystalline silica containing products or materials
- making changes to processes or procedures that generate RCS
- changing or improving controls put in place to protect workers from the risks of silica-related diseases
- resolving health and safety issues
- health monitoring
- monitoring the conditions at the workplace, including air monitoring and
- providing information and training of workers.

It is important that your workers can participate in discussions about health and safety, as they are most likely to know about the risks of their work. You must allow workers a reasonable opportunity to express views before any decision is made. Joint involvement in identifying hazards and assessing and controlling workplace risks will help build a mutual commitment to this process and any changes that may result.

Further information on consultation requirements is in the Code of Practice: Work health and safety consultation, co-operation and co-ordination.

3.2 The risk management process

WHS Act section 17

Management of risks

Risks arising from working with crystalline silica containing materials must be eliminated or minimised so far as is reasonably practicable to protect workers and other persons against harm.

Risk management is a proactive, systematic process that helps a PCBU plan and respond to potential hazards and their associated risks in the workplace.

Risk management involves four steps:

- **Identify hazards**—find out what could cause harm.
- **Assess risks, if necessary**—understand the nature of the harm that could be caused by the hazard, how serious the harm could be and the likelihood of it happening. This step may not be necessary if you are dealing with a known risk with known control measures.
- **Control risks**—work through the hierarchy of risk controls to implement the most effective control measure that is reasonably practicable in the circumstances and ensure it remains effective over time.
- **Review hazards** to ensure the risk level has not changed **and review control measures** to ensure they are working as planned.

Determining what control measures are reasonably practicable includes consideration of the availability and suitability of control measures.

Further information on the risk management process is in the Code of Practice: How to manage work health and safety risks.

3.3 Identify the hazards

To manage risks of exposure to RCS, you must first identify whether RCS is being generated and released into the air during the work. Different types of materials can contain different amounts of crystalline silica (Table 2).

Table 2: Types of stone and the approximate amount of silica they contain.

Type	Amount of crystalline silica (%)
Marble	2
Limestone	2
Slate	20 to 40
Shale	22
Granite	20 to 45 (typically 30)
Natural Sandstone	70 to 95
Engineered stone	Up to 97
Aggregates, mortar and concrete	various

RCS is generated in workplace processes such as crushing, cutting, drilling, grinding, sanding, sawing or polishing of natural stone or manufactured crystalline silica containing products.

A label, product information or safety data sheet (SDS) may not always be available at a workplace or with a product that contains crystalline silica. If you do not have an information sheet or SDS for a product, you might need to talk to your supplier about whether the product contains crystalline silica and how much crystalline silica may be present. Common crystalline silica containing materials and products include:

- natural stone
- engineered stone ¹
- sintered stone
- porcelain products
- composite dental fillings
- manufactured timber
- bricks
- cement
- asphalt
- grout
- mortar
- tiles, and
- even some plastic materials.

Activities that release RCS into the air include:

- excavation, earth moving and drilling plant operations
- clay and stone processing machine operations
- cutting and laying pavers and surfacing
- mining, quarrying and mineral ore treating processes
- road construction and tunnelling
- construction, building and demolition
- brick, concrete or stone cutting
- abrasive blasting (blasting agent must not contain greater than 1 per cent of crystalline silica)
- foundry casting
- angle grinding, jack hammering and chiselling of concrete or masonry
- hydraulic fracturing of gas and oil wells
- pottery
- crushing, loading, hauling and dumping of rock, or muck from tunnelling, and

¹ Engineered stone is defined under Regulation 529A of the Model Work Health and Safety Regulations 2024. Further information is found in the Engineered Stone Prohibition: Guidance for PCBUs.

- clean-up activities such as sweeping or pressurised air blowing of dust.

For information on the prohibition on engineered stone benchtops, panels and slabs and permitted work with legacy engineered stone, refer to the Engineered stone prohibition – Guidance for PCBUs.

Examples of work with potentially harmful exposures to respirable crystalline silica

Fabricating, installing, maintaining and removing crystalline silica containing products

RCS can be made when cutting, grinding, trimming, polishing, removing or blasting crystalline silica containing products or from storing or disposing of dusty waste from these processes.

Mining, quarrying, tunnelling and extractive minerals

Exposure to RCS is a known issue, with high risks of worker exposure during rock crushing and tunnelling activities.

Construction, building and demolition

RCS can be formed on site from brick, stone and concrete cutting using power tools.

3.4 Assess the risks

A risk assessment will help you determine how serious the risk posed by the hazard is, what action is necessary to control the risk, and who is responsible for implementing the control measure.

A risk assessment should be carried out if any of the following apply:

- there is uncertainty about how a hazard may result in a harm
- the work activity involves several different hazards, or
- there is any lack of understanding of how these hazards may interact with each other.

Risk assessments should consider:

- the effectiveness of existing control measures
- how work is undertaken in the workplace
- maintenance and cleaning
- breakdown of equipment, and
- failures of health and safety controls.

The assessment should also:

- identify the type and potential severity of the harm
- consider the number of people potentially exposed to the hazard
- work out the likelihood of harm occurring, and
- consider how frequently the task involving the hazard is done or how close people are to a hazard.

If you have identified RCS at your workplace or identified that it may be generated as part of your work practices, you should consider:

- how, where and for how long workers could be exposed to RCS

- the control measures you have in place to control the dust, and
- the ways you can assess how well your control measures work.

RCS is invisible to the naked eye and can remain in the air for a very long time after work has finished. Larger, visible dust particles settle long before invisible dust particles do, meaning workers can breathe in RCS even if they cannot see it in the air. It is important to consider whether workers (and other people in the workplace but not working directly with crystalline silica) are at risk of exposure.

When assessing risk, you should consider if there are other airborne contaminants (fumes or mists) that workers could also be exposed to. It is important to consider if the control measures protect your workers from all possible exposures.

If your workers are cutting, grinding, sanding, drilling and polishing crystalline silica containing products or carrying out any activities that release RCS into the air, then there is a significant risk that without effective controls they will be exposed to RCS and develop an illness or silica-related disease.

Some tools and processes release more RCS into the air than others. Some crystalline silica containing products or materials contain very high levels of crystalline silica and are considered to pose a significant risk to the health of workers who work with them. Workers who use power tools to cut or grind crystalline silica containing materials (such as circular saws or grinders) can have some of the highest exposures to RCS. These tools are often used to complete fabrication and installation tasks including cutting holes for sinks and stove tops for installation in natural stone benchtops or during shaping and joining of stone pieces.

In areas where hand tools are used, workers performing other tasks may also be exposed to high levels of RCS. Dry cutting, grinding, or polishing crystalline silica containing products without on tool dust extraction, water suppression or local exhaust ventilation generates very high levels of RCS that far exceed the permissible workplace exposure standard.

For further information, please refer to the Code of Practice: Construction work.

Take action to control the risks

As a PCBU, you must eliminate risks arising from exposure to RCS, or if that is not reasonably practicable, minimise the risks so far as is reasonably practicable to workers and other persons at their workplace. If your business uses crystalline silica containing products or materials, you may need to use a combination of control measures to protect your workers from exposure to RCS. You will also likely need air monitoring and health monitoring programs to confirm your control measures are working and your workers are protected.

When managing risks associated with RCS, you must apply the hierarchy of control measures (Figure 2). The hierarchy ranks control measures from the highest level of protection and reliability to the lowest.

You must always aim to eliminate a risk if it is reasonably practicable to do so. Where a risk cannot be eliminated, it must be minimised, so far as is reasonably practicable, using one or more of the following approaches:

- substitution
- isolation, and
- engineering controls.

If the risk cannot be completely managed by the above controls, the remaining risk must be further minimised using administrative control measures, so far as is reasonably practicable. If risk still remains, personal protective equipment (PPE) should be used to control any remaining risks. Cost may also be relevant, but you can only consider this after an effective review of all reasonably practicable control measures. A control measure can only be removed from consideration where the cost of implementing the control is grossly disproportionate to the risk.

The control measures that are the most effective for your workplace will depend on your industry, work processes and the risk of exposure.

From 1 July 2024, PCBUs must comply with specific requirements in relation to controlling the risks of RCS when processing certain manufactured stone and porcelain products.

Specifically, as a PCBU, you must not process, or direct or allow a worker to process porcelain products, sintered stone or engineered stone unless the processing is *controlled*. Please note that engineered stone may only be processed in certain limited circumstances where the engineered stone prohibition does not otherwise apply.

Processing in relation to these products means crushing, cutting, grinding, trimming, sanding, abrasive polishing and drilling using power tools or other mechanical plant.

For processing to be controlled:

- control measures to eliminate or minimise risks arising from the processing of the stone or product must be implemented so far as is reasonably practicable; and
- at least one of the following systems must be used:
 - an effective water delivery system that supplies a continuous feed of water over the stone being processed to suppress the generation of dust,
 - an effective on-tool dust extraction system,
 - an effective local exhaust ventilation (LEV) system, and
- each person who is at risk of exposure to RCS from processing the product must be provided with respiratory protective equipment (RPE) and must wear the RPE while work is being carried out. The RPE must comply with:
 - AS/NZS 1716:2012 (Respiratory protective devices), and
 - AS/NZS 1715:2009 (Selection, use and maintenance of respiratory protective equipment).

More than one control method will normally be required to adequately protect workers.

Elimination

The first thing you must consider is whether a risk can be completely removed from the workplace.

If it is reasonably practicable, eliminate the crystalline silica containing products or materials from your workplace. This will effectively remove the risk of workers being exposed to RCS when working with these products or materials.

In many cases, eliminating crystalline silica containing products or materials may not be reasonably practicable. Elimination may not be possible if RCS is naturally occurring at your workplace or you cannot make the end product or deliver a service without generating it.

If it is not reasonably practicable to eliminate the risk, then risks must be minimised, so far as is reasonably practicable, using the hierarchy of controls.

Substitution

Substitution is where you replace a product with something that is less hazardous and therefore has a lower risk.

Effective substitution of crystalline silica containing products will depend on your workplace and the work tasks your workers carry out. Again, substitution might not be practicable where crystalline silica is naturally occurring or if it means you cannot make the end product or deliver a service.

Substitution can be an effective way of managing the risk of exposure to RCS. For example, you can:

- use products that do not contain crystalline silica or have less crystalline silica in them, or
- use a crystalline silica containing product that does not need to be cut, ground or polished.

Isolation

Isolation involves physically separating the source of harm from people.

This may involve placing barriers or distance between a hazard and your workers.

Isolation is an effective way of protecting your workers from exposure to RCS. Physical barriers that remove the worker from contact with RCS are the most effective form of isolation controls.

Isolation controls include:

- isolating high dust generation work processes within an enclosed room with restricted access (Figure 3)
- providing physical barriers and exclusion zones between different workers and workstations to prevent dust or water mist from moving into other work areas or towards other workers
- distancing a work process from other workers.
 - for example, consider where other workers are working when powered hand tools are used
- designating a room or area for other tasks such as changing or eating, away from the work area.

You can also use barriers around automated tasks to shield workers from RCS.

Wherever possible, workers should not fabricate crystalline silica containing products at the installation site. If modifications at the installation site need to be made, this work should be done outdoors in a designated area, wearing appropriate PPE and using engineering controls, including wet methods and dust collection systems.

Figure 3. An example of an isolation booth used for automated wet cutting

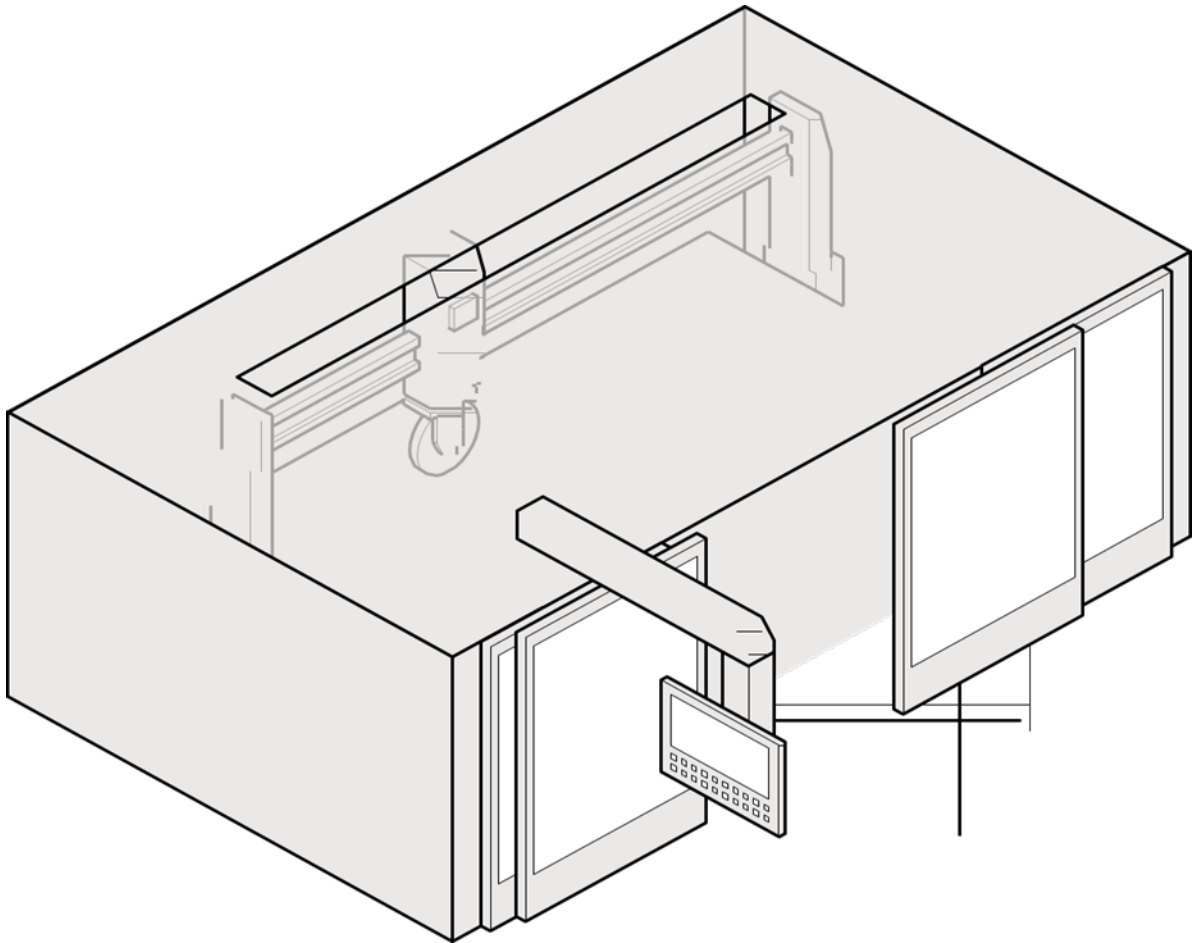

Engineering controls

Engineering controls use physical methods to change the characteristics of a task, including mechanical devices or processes that eliminate or minimise the generation of RCS. Engineering controls to control exposure to RCS can include:

- automation when cutting, grinding or drilling
- using wet cutting methods
- local exhaust ventilation
- drills, routers, saws and other equipment designed to be fitted with local exhaust ventilation and a water attachment to suppress dust
- using sacrificial backer-boards or spoil boards
- fitting large machinery such as excavators and bulldozers with positive pressure enclosed cabs, and
- cleaning up dust with an M or H-class industrial vacuum cleaner.

The selection of reasonably practicable engineering controls for your workplace will depend on the tasks your workers carry out. When considering and using engineering controls, be aware of other hazards that may be introduced. As many engineering controls are motorised you should be aware of noise and vibration levels at your workplace and issue personal hearing protection as needed.

General dust, including dust containing RCS is abrasive and can damage and wear engineering controls. It is important to have a maintenance schedule in place to keep your equipment in good working order. You should regularly inspect your equipment for:

- wear and tear, corrosion or damaged parts
- air leaks in pneumatic tools
- kinks, holes or leaks in water suppression or dust extraction equipment, or
- damage to guards and flaps that contain water spray.

Administrative controls

Administrative controls should only be used to provide additional protection and must only be considered after implementing substitution, isolation and engineering controls.

Administrative controls rely on worker behaviour and it is very important to have administrative policies and worker training when crystalline silica is identified at your workplace. You also need to supervise your workers to make sure they understand and follow your administrative policies.

Examples of administrative controls for RCS include:

- planning cutting tasks to make sure the minimum number of cuts are made
- written rules and policies for working with crystalline silica or cleaning crystalline silica waste
 - for example, having a written clean-up procedure and log
- a maintenance schedule and log for equipment and PPE
- shift rotation policies to make sure workers are not exposed to dust above the workplace exposure standard and for extended periods of time
- restricted area policies so that only staff who are carrying out a task that generates RCS are allowed access to those areas, and
- signage at the workplace highlighting there is a dust hazard and any required use of RPE and other PPE (Figure 4).

Housekeeping

Good housekeeping can eliminate or reduce exposure to RCS, even after work has stopped. Developing written rules and policies for your workplace is a good way to implement housekeeping as an administrative control, and training people in appropriate cleaning methods. For example, you could require your workers to:

- wet down dusty work areas and processes
- conduct a cleaning schedule for work areas and a maintenance schedule for engineering controls
 - for example, regularly cleaning dusty vehicle tracks or high use areas and keeping them wet during the day
- carry out daily cleaning procedures for slurry and settled dust
 - for example, placing wet slurry inside a sealed container for disposal
- never use compressed air, dry sweeping or general-purpose vacuum cleaners to clean surfaces or clothing

- use a low-pressure water, wet sweeping or an M or H class rated vacuum cleaner to clean dusty floors, walls, other surfaces, and equipment,
- always follow the vacuum manufacturer's operator manuals and instructions for changing dust bags and filters
- store dusty PPE and equipment in sealed bags when not in use, and
- clean PPE and equipment in designated areas only.

If your workers are outdoors, you can cover the ground with plastic sheeting and remove remaining dust using the above methods.

Figure 4. Examples of dust hazard signs



Decontamination

Dusty clothing and PPE can expose workers and others to RCS. Examples of how you can minimise exposure to dust carried on PPE and work clothes include:

- using an industrial M- or H- class vacuum cleaner to remove dust from clothes and uniforms:
 - by positioning these units at the exits of dusty work areas, you can encourage workers to vacuum their clothes before leaving
 - you should make sure that workers have access to an area to wash their arms, hands, faces and even their hair.
- providing a laundry service for dusty PPE and work wear supported by a policy, which includes:
 - that dusty PPE and work wear are not to be taken home
 - designated areas where dusty PPE and clothes must be changed
 - when dusty PPE and clothes must be laundered
 - if you use a commercial laundry, dampen the clothes and place them in a sealed, labelled plastic bag, and inform the laundry that the clothes are contaminated with RCS
- requiring workers to change dusty clothing after each shift, or if they have just finished a very dusty task to change at their next break, and
- providing workers with rubber boots and aprons.

Workers' clothes and uniforms must be cleaned frequently to stop RCS from contaminating break rooms, other parts of the workplace and importantly, to stop workers from taking RCS home.

More information about facilities at your workplace can be found in the Code of Practice: Managing the work environment and facilities.

Personal protective equipment

Personal protective equipment (PPE) is the least effective method for controlling risks. However, it can be effective at minimising residual risk when used in conjunction with higher order controls. Before working with crystalline silica containing products, a PCBU, the principal contractor or person in control of the workplace should assess the conditions likely to affect the health and safety of workers and arrange for the provision and use of appropriate PPE. You must provide the PPE required to manage the risks and ensure workers are trained in its correct use.

More information about Personal Protective Equipment can be found in Part 5 of this Guide.

Example risk assessment: Izzy's Paving company

You own a small business that cuts and lays pavers that contain crystalline silica.

Most cutting of pavers is done outdoors using saws. Cutting with a saw is normally carried out with a diamond blade, water suppression and on site. Block splitters are rarely used.

Very fine sand is also used when finishing laying stones. It is dry swept between the pavers.

What is the hazard?

Workers can breathe in RCS when cutting pavers and when sweeping sand.

What is the harm?

Lung damage including cancer, bronchitis and silicosis.

Who may be harmed?

All workers undertaking cutting and sweeping tasks and workers and other people nearby.

What are you doing now?

- water to suppress dust
 - cutting is done close to where pavers are laid
 - some hoses are leaking, and some attachments are broken
 - slurry is not collected
 - sand is dry swept
- PPE for safety (steel-toe boots, protective work wear, hard hats, gloves)
- eye protection to protect worker's eyes
 - some of the goggles are very old
- P2/N95 RPE
 - some workers have beards and these masks do not fit well
- hearing protection (ear plugs) for loud power tools
 - workers nearby cutting don't have ear plugs

What actions and improvements do you need?

- Designate cutting area further from where pavers are laid to minimise dust and noise exposure to other workers.
- Use wet methods to clean up and finish laying pavers as well as for cutting pavers.
- Check and repair water connections and hoses.
- Collect slurry in a pan under the saw for disposal.
- Implement maintenance schedule for equipment and PPE.
- Provide PPE and RPE training for workers.
- Provide health monitoring for workers and others who may be exposed if there is a significant risk to the health of their workers because of exposure to RCS at the workplace.
- Review type of RPE required for tasks.
- Introduce or review a clean-shaven policy for workers cutting pavers.
- Replace old and faulty goggles.
- Provide hearing protection to workers nearby cutting area.
- Conduct air monitoring if there is a risk to a worker's health, or if the PCBU is not certain whether RCS levels exceed the workplace exposure standard.

3.5 Maintain and review control measures

Managing WHS risks is an ongoing process that needs attention over time and particularly when any changes affect the activities carried out at your workplace.

The control measures you put in place should be reviewed regularly to make sure they work as planned. You should review the control measures for high risks more frequently. Don't wait until something goes wrong. A review of your control measures is required:

- when the control measure is not effective in controlling the risk, for example if:
 - a worker's health monitoring report shows an injury, illness or disease
 - the doctor supervising a worker's health monitoring requests a review of your control measures
 - air monitoring shows RCS is at or above 50% of the workplace exposure standard
- before something significant changes at the workplace, for example there is a change to:
 - the workplace itself
 - any aspect of the work environment, and
 - any system of work, process or procedure
- if a new hazard or risk is identified
- if raised by your workers or health and safety representative (HSR) during consultation
- if an HSR requests a review, and
- at least once every five years.

To review your control measures, you can use the same process as when you are identifying a hazard. Consult with your workers and HSR and consider the following questions:

- Are the control measures working effectively in both their design and operation?
- Have the control measures introduced new hazards?
- Have all hazards been identified?
- Have new work methods, new equipment or chemicals made the job safer?
- Are safety procedures being followed?
- Has the instruction and training provided to workers on how to work safely been successful?
- Are workers actively involved in identifying hazards and possible control measures? Are they openly raising health and safety concerns and reporting problems promptly?
- Are the frequency and severity of health and safety incidents reducing over time?
- If new information becomes available, does it show that your current controls may no longer be the most effective?

If you find that the control measures may not be sufficient, go back through and review your information and make further decisions about risk control.

3.6 Information, training, instruction and supervision

You must, so far as is reasonably practicable, provide any information, instruction, training or supervision necessary to protect people from health and safety risks that arise from the work carried out as part of the business or undertaking.

You must ensure that information, training or instruction provided to a worker is suitable and adequate for:

- the nature of the work carried out by the worker
- the nature of the risks associated with the work when the information, training and instruction is given, and
- the control measures implemented.

You must also ensure, so far as is reasonably practicable, that the information, training, and instruction are provided in a way that is readily understandable for the person to whom it is provided.

Training must be provided:

- as part of induction and refresher training
- to a worker who will be carrying out a particular task or activity where RCS is present or could be generated, and
- when significant changes are made at the workplace that change how workers might be exposed.

Training should give workers a good understanding of:

- what RCS is and its health effects
- what controls are in place to protect them
- when they might be at risk of exposure including
 - work practices that breach the PCBU's instructions or policies, or
 - when controls might not be effective, and
- what to do if they observe unsafe practices at the workplace.

You should encourage your workers to report hazards and health and safety problems immediately. This is important because it allows the risks to be managed before an incident or illness occurs.

3.7 Safe Work Method Statements

WHS Regulation Part 6.3 Division 2

High risk construction work – safe work method statements

'Construction work' is defined in the WHS Regulations as any work carried out in connection with the construction, alteration, conversion, fitting-out, commissioning, renovation, repair, maintenance, refurbishment, demolition, decommissioning or dismantling of a structure.

Regulation 291 of the WHS Regulations sets out a list of construction work that is high risk for the purposes of the Regulations, and for which a safe work method statement (SWMS) is required. This includes work 'carried out in an area that may have a contaminated or flammable atmosphere'.

Processing of crystalline silica containing materials may be considered high risk construction work if RCS may contaminate the work atmosphere.

A SWMS is required because it helps a PCBU clearly communicate to all workers at the construction site any health and safety risks and how they will be managed.

Further information on SWMS can be found at worksafe.nt.gov.au/forms-and-resources/bulletins/safe-work-method-statement-for-high-risk-construction-work.

4. Ventilation and wet cutting

Ventilation is a very effective engineering control when designed correctly. There are a range of different ventilation systems and you need to use the ones that suit your workplace and the tasks your workers carry out.

Local exhaust ventilation can be used to remove RCS close to the source before it reaches the breathing zone of a worker. Figures 5 to 7 show on tool dust extraction and local exhaust ventilation.

More information about ventilation and other engineering controls can be found in the Code of Practice: Managing risks of hazardous chemicals in the workplace.

Figure 5. A worker cutting/grinding with on-tool dust extraction

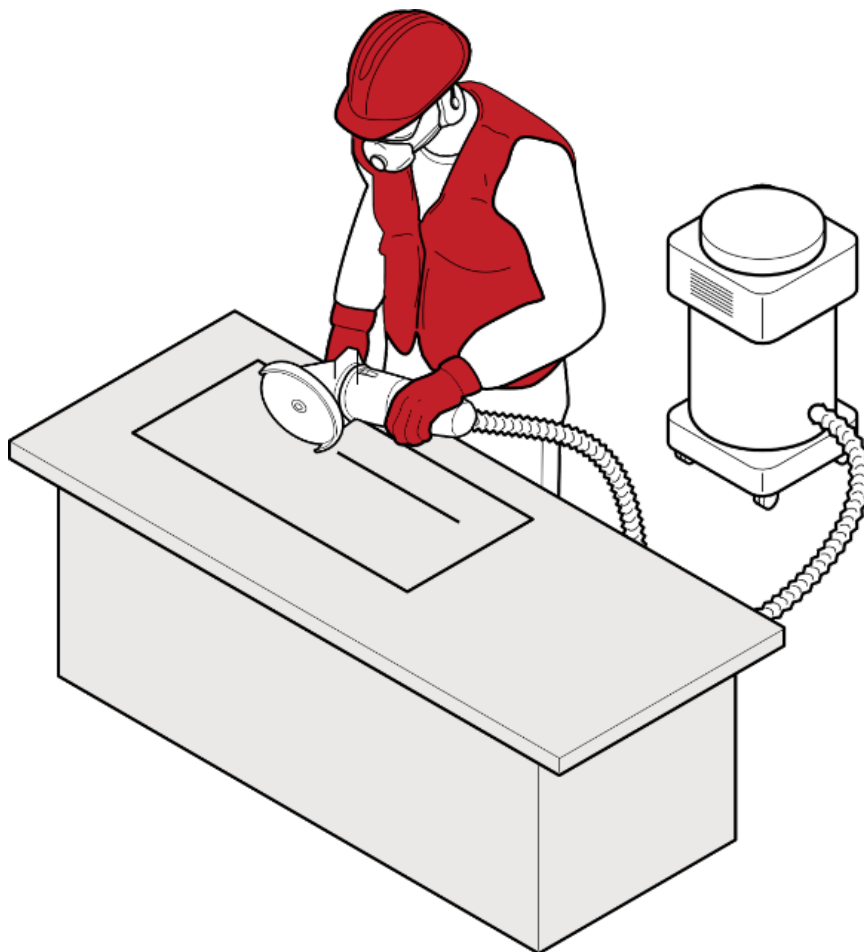

Figure 6. Operational view of local exhaust ventilation

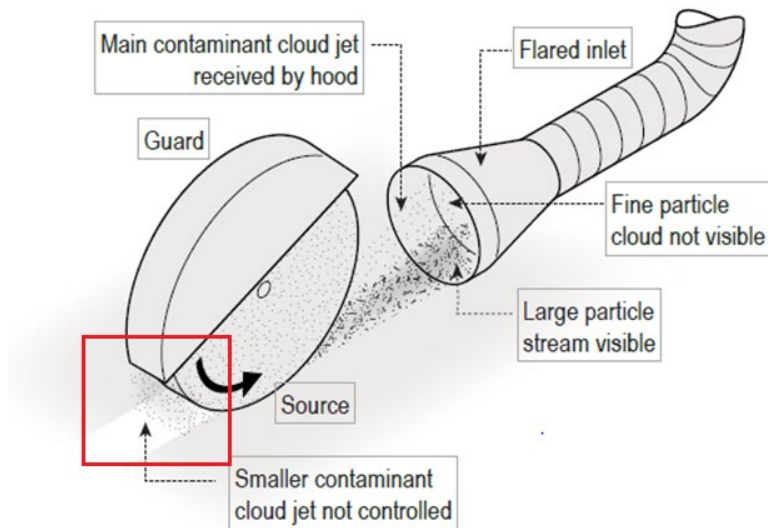
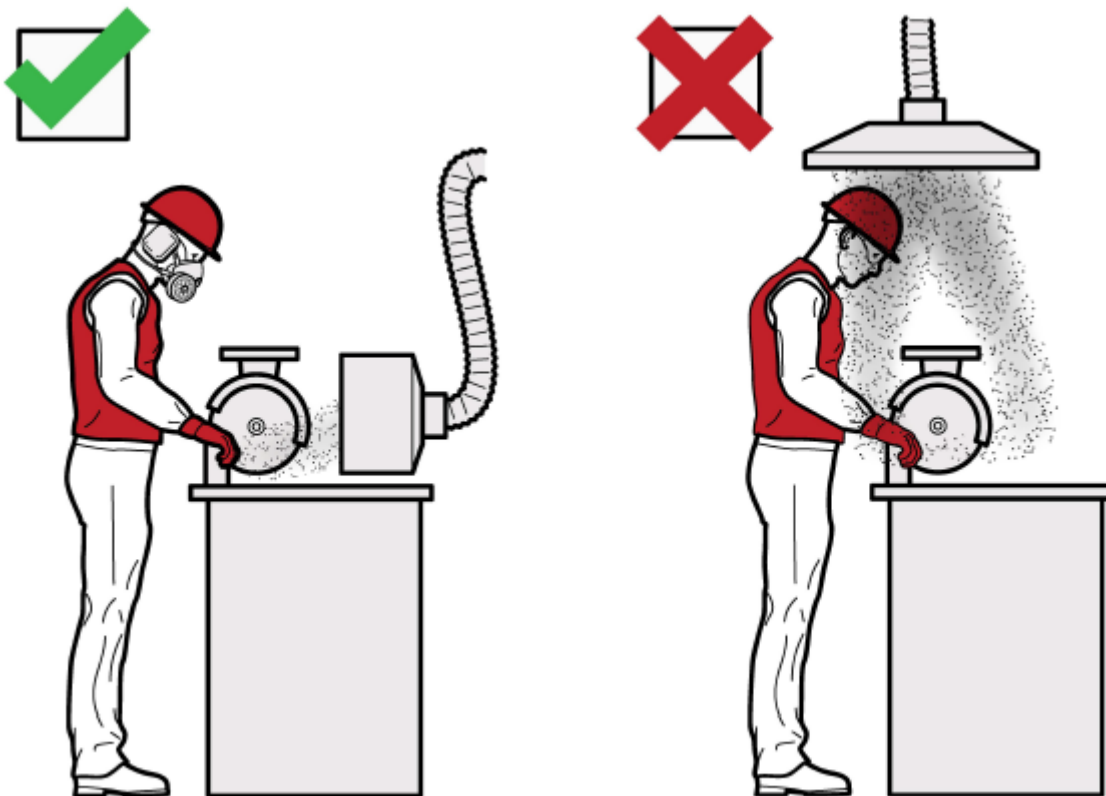

Figure 7. Examples of using local exhaust ventilation



Research has found that even when wet methods are used on products that contain high levels of crystalline silica that RCS may not be adequately controlled. Applying water to rotating tools can also generate RCS-contaminated mist that must also be controlled.

For this reason, properly designed water suppression and local exhaust ventilation may be required in combination when working with these products. It is important to:

- only use tools and machinery that have been specifically designed for use with water attachments with the appropriate ingress protection (IP), for example:
 - when cutting natural, engineered and sintered stone or porcelain slabs, use bridge saws fitted with water attachments to suppress dust
 - to complete sink and stovetop cut outs, use water suppressed routers, water jet cutters or bridge saws
 - for brick and concrete cutting, use hand-held power tools fitted with multiple water feeds that deliver water to the cutting blade and use water suppressed wet edge milling machines or polishing machines
- use an adequate number of water feeds to prevent visible dust during the process
- maintain adequate water pressure (0.5 L/min or as specified by the manufacturer) to make sure water is reaching the product or tool
- control water spray using guards, plastic flaps or brush guards
- prevent workers from being able to turn water suppression systems down or off during operation
- only use tools and machinery that have been specifically designed for local exhaust ventilation attachments such as drills, circular saws and grinders equipped with a shroud and an M- or H- class rated vacuum
- install fixed, portable or flexible capturing hoods to capture dust at the point of generation, and
- suppress dust by using water sprays to reduce airborne dust and dust clouds (for example, during earthworks, on stockpiles and roads, and when using machinery and cutting equipment).

The use of a handheld spray bottle, sponge or garden hose to separately apply water to rotating tools is not adequate to suppress RCS.

Wet methods of fabrication can introduce other hazards to your workplace. When using wet methods consider:

- installing ventilation to control water mist that may carry dust in the mist cloud
- providing waterproof aprons, waterproof non-slip footwear and eye protection that does not fog up and obstruct worker's vision
- filtering water that is recycled
- ensuring run-off is effectively drained away from equipment and work areas
- installing non-slip flooring
- implementing housekeeping policies to make sure run-off does not dry to create a dust hazard, and
- if you are working outside with wet methods and it is very cold, check for ice hazards.

5. Personal Protective Equipment

You should never rely solely on PPE to protect workers from RCS as it does not prevent dust generation. It is the least effective form of controlling dust exposure and relies on correct fit and use by the worker, as well as adequate supervision.

Before using PPE, you need to do a risk assessment to see what other controls can and should be used. PPE should only be considered after implementing substitution, isolation, engineering and administrative controls. It should only be used to supplement higher-level control measures or when no other safety measures are available. Figure 8 illustrates some examples of PPE.

There are requirements under the WHS laws when it comes to choosing and using PPE.

You must make sure the PPE you provide is appropriate (check the crystalline silica containing product's SDS if one is provided) and fits the worker who will be wearing it. This will ensure that the PPE is doing its job. Wrong or ill-fitting PPE means that RCS can harm your workers. For example, the dust can get into worker's eyes or into the worker's breathing zone and into their lungs.

You must make sure PPE is clean, hygienic and in good working order. This is so that you do not introduce other hazards to the worker and that the PPE will work as intended. Information about maintaining and cleaning PPE should be sourced from the manufacturer or supplier.

You must provide ongoing training, information and instructions for your workers on how to use, clean and store the PPE you provide. Workers must take reasonable care for their own health and safety. They are required to follow reasonable instructions and cooperate with any workplace policies you have in place to protect them. Workers must use and wear PPE as instructed by you. However, you must also supervise your workers to check they understand their training and are using the PPE correctly.

Figure 8. Personal protective equipment

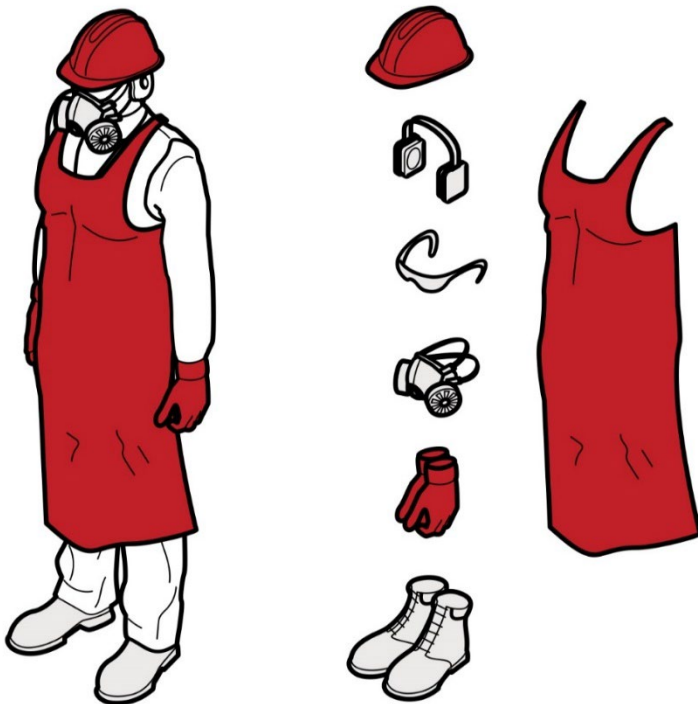

Respiratory protective equipment (RPE)

As RCS particles are very small, workers should use a tight-fitting respirator with an effective face seal. This means they need to be clean-shaven or only have facial hair that does not interfere with the fitting surfaces or the respirator valve. As everyone's face is a different size and shape, there is no 'one size fits all' tight-fitting respirator. This means that you should also fit test each worker and their RPE before they undertake dusty work.

For workers who want to keep facial hair that may interfere with the operation or proper fit of tight-fitting respirator (for example a closely trimmed beard), a powered air purifying respirator with a loose hood may be suitable.

Fit testing Respiratory Protective Equipment

Fit testing measures the effectiveness of the seal between the respirator and the wearer's face. If there is not a good seal contaminated air, potentially containing RCS, could leak into the respirator and be breathed in by the worker.

Workers should pass a respirator fit test before they first start wearing a tight-fitting respirator including:

- half face disposable
- half face reusable
- full face reusable, and
- tight-fitting powered air purifying respirators (PAPR).

Types of RPE are shown in Figure 9.

There are two types of fit testing that can be carried out:

- Qualitative
 - a pass/fail test that relies on the wearer's ability to taste or smell a test agent
 - only used on half face respirators, and
- Quantitative
 - uses specialised equipment to measure how much air leaks into the respirator
 - used on half face respirators, full face respirators and PAPR.

Quantitative fit testing results are more objective than qualitative testing because some workers have difficulty with their ability to taste or smell. This can result in a 'false pass' and worker health not being adequately protected.

It is recommended that full face respirators and PAPR are fit tested using the quantitative method.

All fit testing must be carried out by a competent person, manufacturer, supplier or consultant:

- before a worker wears a tight-fitting respirator for the first time
- each time a new make or model of respirator is provided to a worker, and

- whenever there is a change in the wearer's facial characteristics or features that may affect the seal (e.g. large weight loss or gain), and
- be repeated annually.

Fit testing should be repeated on a regular basis and based upon the outcomes of a risk assessment (e.g. every one or two years).

For RPE to be effective, workers who are required to wear tight-fitting respirators must be clean shaven. If they cannot be clean shaven, ensure:

- There is no hair between their face and the seal of the respirator face piece as it can interfere with a proper fit. This is important as RCS is smaller than facial hair.
- Facial hair does not interfere with the inhalation/exhalation valve operation.

Keep a written record of fit tests carried out for each worker and share the record with the worker after fit testing is complete. The record should include the:

- •type of test performed
- •make, model, style and size of respirator tested, and
- •date and result of the test.

You must provide training for your workers who are provided with RPE. This is to make sure they fit, use and maintain the RPE they are expected to use. Training must be provided by a competent person; this could be a consultant, someone in house or a representative from a RPE manufacturer or supplier.

Good training for RPE should cover:

- why the RPE is required for their job
- when the worker must wear the RPE
- how the RPE works
- the limitations of the RPE
- how to correctly put on and take off the RPE
- how to fit check
- how to clean and maintain the RPE
- when and how to replace the filters, and
- how and where to store RPE when not in use.

Fit checking Respiratory Protective Equipment

Fit checking enables workers to take reasonable care of their own health and safety while working with crystalline silica containing products.

A fit check is a quick check to ensure a fit tested respirator is properly positioned on the face and there is a good seal between the respirator and face. Fit checks do not replace the need for a fit test. Workers should follow the respirator manufacturer's instructions on how to carry out a fit check.

Fit checking is the responsibility of the worker. Workers must be trained on how to carry out a fit check for their tight-fitting RPE. They should undertake a fit check every time they use a tight-fitting respirator

to ensure they are using and wearing RPE in a way that will protect their health and safety. For RPE to be effective, workers who are required to wear tight-fitting respirators must be clean shaven.

Figure 9. Respiratory protective equipment

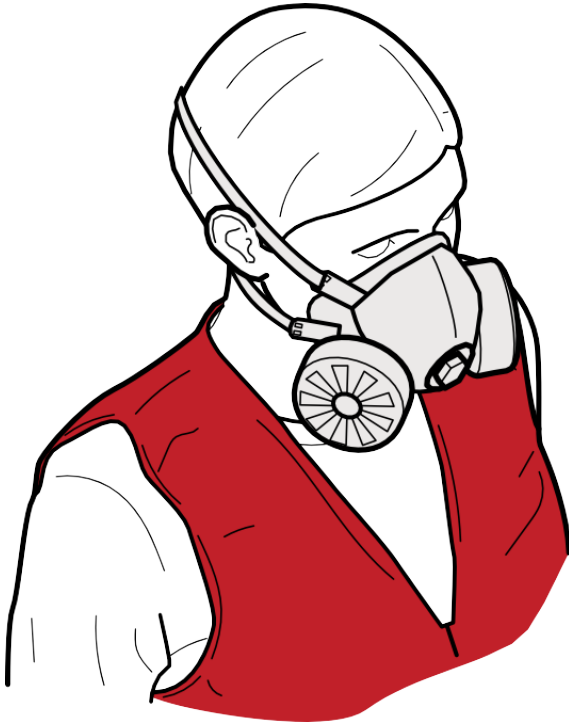

Reusable half-face respirator



Full face Powered Air Purifying Respirator (PAPR)

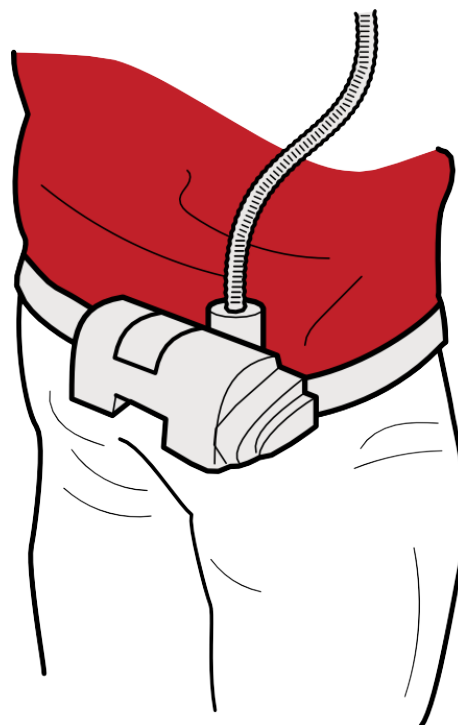

Full face respirator (cartridge)

The PPE you select must also be appropriate for other risks that might arise when working with crystalline silica containing products such as:

- eye protection
- aprons, footwear, and gloves
- hard hats, and
- personal hearing protection.

As discussed above, training for workers by a competent person is essential and you should supervise your workers to make sure they understand their training and are using their PPE correctly.

You can find more information on the [Safe Work Australia webpage: Personal protective equipment](#).

6. Monitoring

6.1 Air monitoring

There is a workplace exposure standard for RCS that must not be exceeded. The workplace exposure standard in Australia is 0.05 mg/m³.

You must do air monitoring to determine the airborne concentration of RCS at your workplace if:

- you are not certain if you are exceeding the exposure standard, or
- monitoring is necessary to find out if there is a risk to health.

Air monitoring can help in assessing the risk to your workers because it can show:

- how much your workers are being exposed
- which processes or products are the source of the exposure, and
- if your current control measures are working.

Air monitoring to determine a worker's exposure involves measuring the level of RCS in the breathing zone of workers using a personal sampler during their usual shift activities, including routine breaks. Figure 10 shows an approximation of a worker's breathing zone.

Figure 10. Worker's breathing zone



A competent person should conduct your air monitoring, for example a certified Occupational Hygienist.

You must keep records of air monitoring for at least 30 years. You must also make sure that your workers can access these records. An air monitoring report should include:

- the background and purpose of the air monitoring including the current workplace exposure standard
- the task to be measured including work patterns and hazards involved with this task
- the control measures in place and their performance
- what sampling and measurements were taken (long and short-term) including information on the calibration of the sampling equipment
- specifics of how sampling was taken
- how and where the samples were analysed including information on the calibration of the analysis equipment
- an interpretation of the results:
 - exposure sources
 - adequacy of current control measures
 - assessment of risk including identification of tasks not measured that are likely to be an exposure source and any workers that could be exposed but were not measured, and
 - compliance with WHS laws
- recommendations, for example:
 - dust control action plan
 - changing control measures and work practices
 - worker training
 - further air monitoring, and
 - health monitoring.

Air monitoring at workplaces that work with crystalline silica containing products

There is insufficient evidence to show that any one combination of controls is guaranteed to keep exposure below the workplace exposure standard when working with crystalline silica containing products.

When working with crystalline silica containing products, air monitoring will be needed to confirm whether the exposure standard for RCS is being exceeded.

It is recommended that air monitoring is carried out:

- at least once a year if you work with crystalline silica containing products
- if a worker becomes unwell or if a health monitoring report recommends you review your control measures

- if your work practices or the types of tools used change
 - for example, you use a new tool more often, and
- if new control measures are implemented or you change your control measures
 - for example, if you install an isolation booth or ventilation, or apply a new shift rotation, or
 - an HSR requests a review of control measures.

6.2 Health monitoring

If there is a risk to the health of your workers because of exposure to RCS, you must organise and pay for health monitoring. This includes workers who are not directly generating dust but may be in the vicinity of RCS or in contact with RCS in other ways such as through cleaning work areas or equipment.

Some crystalline silica containing products contain very high levels of crystalline silica and are considered to pose a significant risk to the health of workers who work with them. You should also consider providing health monitoring to other workers who might be exposed to dust from these processes. This includes workers who are exposed to dust while cleaning or those who perform administrative work in the vicinity of fabricating products containing high levels of crystalline silica. Workers who may be provided health monitoring include:

- Shapers
- saw operators
- finishers
- CNC router and water jet operators
- Polishers
- excavators
- jackhammer operators
- abrasive blaster
- pavers cutting concrete blocks
- labourers, and
- supervisors.

Health monitoring should begin at the time a worker is first employed or when they first start working with crystalline silica and crystalline silica containing products. This is so any changes to the worker's health can be detected. If your workers are at risk of exposure to RCS and you have not provided health monitoring, you must organise it as soon as possible.

Health monitoring must be carried out or supervised by a doctor with experience in health monitoring. Health monitoring for RCS exposure includes workers being screened with specialised equipment. Depending on the worker's past exposures and medical history, some doctors may recommend carrying out further tests with a specialist to detect early stage silicosis.

Under WHS laws, the minimum requirements for health monitoring for crystalline silica through exposure to RCS are:

- collection of demographic, medical and occupational history
- records of personal exposure
- standardised respiratory questionnaire
- standardised respiratory function tests, for example, FEV1 (forced expiratory volume in one second), FVC (forced vital capacity) and FEV1/FVC and
- chest X-ray full posterior-anterior (PA) view.

All full-size PA chest X-rays should be taken in a specialist radiology practice or hospital department. The X-rays should be read by a radiologist who meets the reporting requirements and competencies of the Royal Australian and New Zealand College of Radiologists or is qualified as a 'B reader'. A B reader is a radiologist who has undertaken specialised training to detect dust lung diseases such as silicosis, coal workers pneumoconiosis, mixed dust pneumoconiosis and progressive massive fibrosis (PMF).

High-resolution computed tomography (HRCT) is more sensitive and effective than X-rays in the early detection of silicosis. A low dose HRCT scan of the chest (non-contrast) may be used by the registered medical practitioner supervising or carrying out the health monitoring, depending on the worker's history and levels of crystalline silica exposure. Given the high risks posed by working with engineered stone, low dose HRCT may be used instead of, or as an adjunct to, X-ray. Alternative imaging methods are being developed and may also be considered.

The doctor doing your health monitoring will provide you with a health monitoring report. They must be kept for at least 30 years and the worker must receive a copy of the report.

You must provide the health monitoring report to NT WorkSafe if the doctor doing your monitoring:

- informs you that a worker may have contracted a disease, injury, or illness as a result of carrying out work using, handling, generating, or storing crystalline silica, or
- recommends that you take remedial measures (such as removing a worker from work).

In some jurisdictions, the doctor may notify a worker's disease diagnosis to the Department of Health.

If you are a PCBU that provides health monitoring, particularly if you share your duties with another duty holder, please seek further information from Safe Work Australia's the [Health monitoring guide for PCBUs](#) and [Health monitoring guide for crystalline silica](#).