

Guide

Managing the risks of machinery in rural workplaces

Disclaimer

This publication contains information regarding work health and safety. It includes some of your obligations under the *Work Health and Safety (National Uniform Legislation) Act* – the WHS Act – that NT WorkSafe administers. The information provided is a guide only and must be read in conjunction with the appropriate legislation to ensure you understand and comply with your legal obligations.

Acknowledgement

This guide is based on material produced by Safe Work Australia at www.swa.gov.au



Creative Commons

All material presented in this publication is provided under a Creative Commons Attribution 3.0 Australia licence.

For the avoidance of doubt, this means this licence only applies to material as set out in this document.

The details of the relevant licence conditions are available on the Creative Commons website as is the full legal code for the CC BY 3.0 AU licence.

Version: 1.0

Publish date: March 2016

Contents

| | |
|---|----|
| Contents..... | 3 |
| Introduction | 4 |
| Who should use this guide?..... | 4 |
| What is a rural workplace?..... | 4 |
| Who has work health and safety duties under the law?..... | 5 |
| How can plant risks be managed?..... | 6 |
| Using plant in rural workplaces | 8 |
| Tractors..... | 13 |
| Farm vehicles..... | 20 |
| Quad bikes..... | 22 |
| Plant not in use | 27 |
| Altering plant..... | 28 |

Introduction

This Guide provides information on how to manage the risks of machinery, vehicles and other types of plant used in rural workplaces.

Who should use this guide?

This Guide applies to all rural workplaces where machinery and other types of plant are used. Some of the principles outlined in this Guide may also apply to workplaces other than rural workplaces. For example, this Guide can be used for municipal services or green keeping.

Plant commonly used at a rural workplace includes:

- machinery e.g. planters, harvesters, balers, cultivators, pickers, grain augers, and elevators
- powered mobile plant e.g. tractors, front-end loaders (FELs), harvesters and mowers
- on-farm vehicles e.g. quad bikes, motor bikes, farm utes and modified vehicles (such as bull catchers)
- tools and equipment powered by an energy source or manually operated e.g. manually or mechanically powered grain augers, power take-offs or power input connections, slashers, brush cutters, chainsaws, posthole diggers, baling presses, post drivers and workshop tools like drills and grinders or welding plant, irrigation equipment, pumps, generators, silos and hoppers, and
- a component or anything fitted or connected to the item of plant e.g. a tractor-mounted post-driver.

What is a rural workplace?

A **rural workplace** is a place where primary production and land management is carried out including:

- cultivating and harvesting agricultural crops or products, whether grown for food or not
- rearing and managing livestock
- shearing, skirting, classing, scouring, sorting or pressing of wool
- aquaculture
- feral animal and weed control
- horticulture or amenity horticulture, and
- clearing, fencing, trenching, establishing farm infrastructure, draining or otherwise preparing land for a purpose identified above.

It is a workplace even when work is not being actively carried out. People who live at the rural workplace including children and other family members and visitors who might be around plant are owed a duty of care by the person who conducts the business or undertaking.

Who has work health and safety duties under the law?

Everyone in a rural workplace has a work health and safety duty. The main duties are set out in Table 1.

Table 1 Duty holders and their obligations

| Who | Duties |
|---|--|
| <p>A person conducting a business or undertaking</p> | <p>A person conducting a business or undertaking (PCBU) has the primary duty to ensure, so far as is reasonably practicable, workers and other people are not exposed to health and safety risks arising from the business or undertaking.</p> <p>This duty requires the person to manage risks by eliminating health and safety risks so far as is reasonably practicable, and if it is not reasonably practicable to eliminate the risks, by minimising those risks so far as is reasonably practicable. It also includes ensuring so far as is reasonably practicable the:</p> <ul style="list-style-type: none"> ■ provision and maintenance of safe plant, and ■ safe use, handling, storage and transport of plant. <p>The Work Health and Safety (WHS) Regulations include specific duties for a PCBU with management or control of plant, powered mobile plant and plant that lifts or suspends loads. If you own plant including for use at a rural workplace, you are the person with management or control of that plant.</p> <p>If you hire or lease plant, you have management or control of that plant for the period you have hired it. Both you and the person you have hired or leased it from will have duties to eliminate or minimise the risks associated with the plant, so far as is reasonably practicable.</p> |
| <p>Designers, manufacturers, suppliers and importers</p> | <p>Designers, manufacturers, importers and suppliers of plant must ensure, so far as is reasonably practicable, the plant they design, manufacture, import or supply is without risks to health and safety. This duty includes carrying out analysis, testing or an examination and providing specific information about the plant. Information must, so far as is reasonably practicable, be passed on from the designer through to the manufacturer and supplier to the end user. An agent selling equipment who does not take possession of the plant does not have a duty as a supplier e.g. selling used agricultural plant at a clearing sale.</p> |
| <p>Officers</p> | <p>Officers, such as company directors, have a duty to exercise due diligence to ensure the business or undertaking complies with the WHS Act and Regulations. This includes taking reasonable steps to ensure the business or undertaking has and uses appropriate resources and processes to eliminate or minimise risks from plant at the rural workplace.</p> |
| <p>Workers and others</p> | <p>Workers and other people at the workplace must take reasonable care for their own health and safety, co-operate with reasonable policies, procedures and instructions and not adversely affect other people's health and safety.</p> |

How can plant risks be managed?

The following steps must be used to decide what is reasonably practicable to ensure workers and other people are not injured by plant in a rural workplace:

Find out what could cause harm

The following can help you identify potential hazards:

Observe the workplace to identify areas where people use plant. Check the layout of your rural workplace; if work is done close to public areas where traffic volumes are higher, identify potential blind spots and other areas of poor visibility.

- Inspect each item of plant in your workplace and observe how it is used. Think about all the activities that may be carried out during the life of the plant at your workplace, such as installation, commissioning, operation, inspection, maintenance, repair, transport, storage and dismantling.
- Ask your workers, contractors and visitors about plant problems they encounter at your rural workplace.
- Review your maintenance and incident and injury records including near misses.

Assess the risk

In many cases the risks and related control measures will be well known. In other cases you may need to carry out a risk assessment to identify the likelihood of somebody being harmed by the hazard and how serious the harm could be.

Most incidents involving plant at rural workplaces are from:

- vehicle or powered mobile plant rollovers
- maintenance activities, and
- collisions between pedestrians and vehicles reversing, loading and unloading.

A risk assessment can help you determine what action you should take to control the risk and how urgently the action needs to be taken.

Take action to control the risk

The WHS laws require a PCBU to do all that is reasonably practicable to eliminate or minimise risks.

The ways of controlling risks are ranked from the highest level of protection and reliability to the lowest. This ranking is known as the hierarchy of risk control. You must work through this hierarchy to manage risks (see Figure 1).

The first thing to consider is whether plant related hazards can be completely removed from the workplace. For example, risks can be **eliminated** by physically separating pedestrian routes from vehicle areas with physical barriers or conducting activities at times when pedestrians are not present.

If it is not reasonably practicable to completely eliminate the risk then consider the following options in the order they appear below to minimise risks:

- **substitute** the hazard for something safer e.g. replace a quad bike with a side-by-side vehicle (SSV) to reduce the risk of rollover
- **isolate** the hazard from people e.g. use a guardrail or fence to isolate people like workers, children or bystanders from work areas where hazardous plant is used, and
- use **engineering controls** e.g. provide a seat belt on a tractor or install guards to cover rotating or moving parts of machinery.

If after implementing the above control measures a risk still remains, consider the following controls in the order below to minimise the remaining risk, so far as is reasonably practicable:

- use **administrative controls** e.g. install signs and train workers in the proper procedures for operating plant, or
- use **personal protective equipment (PPE)** e.g. high visibility clothing, gloves, hats, hearing protection, and eye protection.

Figure 1: The hierarchy of risk control

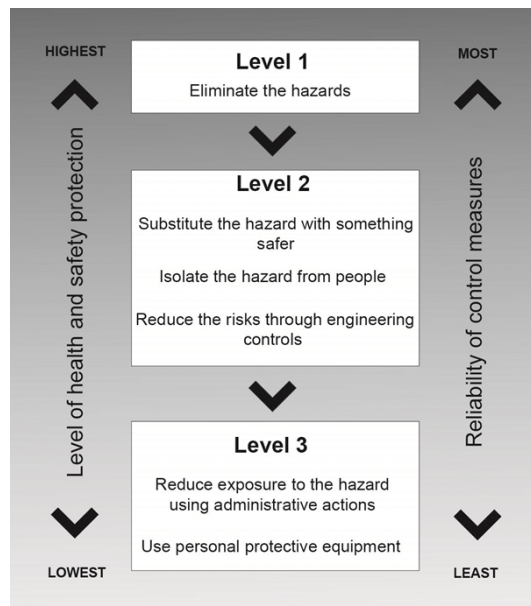

A combination of the controls set out above may be used if a single control is not enough to minimise the risks.

You need to consider all possible control measures and make a decision about which are reasonably practicable for your workplace. Deciding what is reasonably practicable includes assessing the availability and suitability of control measures, with a preference for using substitution, isolation or engineering controls to minimise risks before using administrative controls or PPE. Cost may also be relevant, but you can only consider this after all other factors have been taken into account.

Check your control measures

Check your control measures regularly to make sure they are working as planned. Control measures need to be regularly reviewed to make sure they are effective, taking into consideration any changes, the nature and duration of work and that the system is working as planned.

Further information on the risk management process is in the Code of Practice: *How to manage work health and safety risks*.

Who is involved?

You must consult your workers and their health and safety representatives (if any) when deciding how to manage the risks of plant in the rural workplace.

If there is more than one business or undertaking involved at your workplace you must consult them to find out who is doing what and work together so risks are eliminated or minimised so far as is reasonably practicable.

This may involve discussing site-specific requirements including entering and exiting the workplace, vehicle parking, delivery areas, scheduling suitable times for loading and unloading, refuelling plant and work priorities.

Further information on consultation requirements is in the Code of Practice: *Work health and safety consultation, co-operation and co-ordination*.

Using plant in rural workplaces

Choosing plant

Before choosing plant you should discuss your needs with users of similar plant and plant suppliers to identify plant that is most suited to the workplace and the work it will be used for.

For example, an SSV may be more suitable to use in rugged, steep terrain than a quad bike.

Second-hand plant is more likely to have out-dated or missing safety features. Suppliers of second-hand plant must do what is reasonably practicable to supply equipment that is safe to use at work.

Some considerations when choosing plant are:

- Are operator protective devices fitted? e.g. rollover protective structures (ROPS)
- Is contact with or access to dangerous parts prevented? e.g. engine and battery compartment guarding
- Is it of sturdy construction and has tamper-proof design? e.g. will endure rural workplace conditions
- Does it have fail-safe operation? e.g. simple design and clear operator controls
- Is it easy to inspect and maintain? e.g. assists regular activities to maintain equipment properly
- Does it introduce other hazards into your workplace? e.g. hazardous manual tasks

- Is there safe entry and exit? e.g. enough steps and handholds
- Does it have low noise and vibration? e.g. through a sprung and adjustable seat
- Is there good visibility? e.g. adjustable rear vision mirrors of large enough size
- Are flow restrictors or similar, fitted to hydraulic lines to prevent free fall in the event of hydraulic hose failure? e.g. when lifting and suspending loads.

Design and item registration

The WHS Regulations list certain plant designs and items of plant which must be registered before they can be used. This is known as 'registrable plant'. Registrable plant used in rural workplaces commonly includes large capacity boilers, elevating work platforms (EWP) and cranes.

A person with management or control of registrable plant must keep a record of that plant.

Transporting plant

Before transporting plant you must check the plant is secured and risks to health and safety are eliminated or minimised so far as is reasonably practicable. The local road and traffic authorities may have requirements when transporting plant on a public road like over-width permits.

You must also consider the risk of plant contacting overhead electric lines, for example when relocating a grain silo, grain harvester, field bins, a windmill or emptying tip trucks.

You should contact electricity supply authorities to find out what you need to do when there is a risk of contacting overhead electric lines.

Other essential services like water, gas or telecommunications should be checked to make sure the proposed plant relocation does not interfere with those services.

Workplace layout

If there is a possibility of powered mobile plant (including vehicles) colliding with pedestrians or other vehicles you must ensure the plant has a warning device that will warn people of the plant's movement, for example reversing alarms.

You should also:

- set up the workplace so plant and pedestrians are separated and their paths do not cross
- provide dedicated loading and unloading areas, and
- provide high-visibility clothing and markings for workers, plant operators and plant.

Information, training, instruction and supervision

Before plant is used in your workplace you must provide anyone who will use it with the information, training, instruction or supervision necessary to protect them from associated risks.

You should develop safe work procedures that include instructions and information on:

- position, function and operating sequence of controls and instruments of the plant including operator protective devices as required
- relevant design features of the plant and centre of gravity
- attachments and components that can be used with the plant
- who may use an item of plant e.g. only authorised or licensed operators
- how to safely access and operate plant
- operating conditions in work areas including road rules, rights of way and clearances from overhead electric lines
- procedures for reporting a fault, unsafe practice, damage to the plant, incident or near misses
- how to carry out inspections, cleaning, repair, maintenance and shut-down, and
- emergency procedures.

You must also provide safety information to anyone installing, commissioning, using, testing, decommissioning, dismantling or disposing of plant. This should include information on the types of hazards and risks the plant may pose to them when they are carrying out these activities.

Consider providing information to visitors and family members about the risks from plant that may be operating near them.

Information, instruction and training programs should be practical and 'hands on' and take into account the nature of the work, the risks associated with the work and the control measures. Instruction and training should be delivered so that it is easy for workers to understand. For example, take into account their literacy levels, work experience and the specific skills and physical attributes required for safe use of the plant.

Effective supervision should be provided to all visitors and other family members who might be moving around operating plant. You should correct unsafe work practices as soon as possible or workers may think these are acceptable.

Operating plant

A person with management or control of plant in a workplace must manage risks to health and safety associated with plant including when the plant is being operated.

The person operating the plant must, so far as is reasonably practicable, be provided with the information, training, instruction or supervision necessary to protect them and others from risks to their health and safety. Operators should have easy access to the manufacturer's instructions for safe operation of the plant.

The operator must take reasonable care to operate the plant in a way that does not adversely affect the health and safety of other people including visitors and family members who might be nearby. The person with management or control of plant must take all reasonable steps to ensure that plant is used only for the purpose for which it was designed according to the manufacturer's instructions, unless the person has determined that the proposed use does not increase the risk to health or safety.

Certain types of plant like ride-on forklift trucks, boom-type EWPs and some types of cranes require the operator to have a high risk work licence before they can operate them. The WHS Regulations set out the classes of high risk work licences and the types of plant involved. You must make sure your workers have the relevant licence before they operate the plant.

Working near electric lines

You must ensure, so far as is reasonably practicable, that no person or plant at the rural workplace comes within an unsafe distance of an overhead or underground electric line.

If this is not reasonably practicable then you must carry out a risk assessment and implement control measures to manage the risks. The control measures must be consistent with any requirements of the Electricity Supply Authority.

Aircraft are commonly used at rural workplaces for mustering and crop-spraying. While aircraft are regulated under separate legislation it is important that you bring the location of overhead electric lines to the pilot's attention to avoid wire strike incidents.

Further information about electrical safety is in the *Guide for operating cranes and mobile plant near overhead electric lines* and from the electricity regulator.

Guarding

A guard is a physical or other barrier which prevents contact with moving parts or minimises access to dangerous areas of plant.

For example, guarding should:

- be of solid construction and securely mounted to resist impact or shock
- make bypassing or disabling the guard whether deliberate or accidental as difficult as is reasonably practicable e.g. a physical barrier that can only be altered or removed with a tool
- not create a risk in itself e.g. obstruct operator visibility, weaken the plant, cause discomfort to operators or introduce new hazards like pinch points, or rough or sharp edges
- be properly maintained
- control the risk of things being ejected, and
- be able to be removed when the plant is not in normal operation to allow for maintenance and cleaning (when the guarding is removed the plant must not be able to be restarted unless the guard is replaced).

Plant with hot parts or material

Contact with hot plant parts or material ejected from plant may cause serious burns e.g. tractor exhaust system or molten material from welding. Control measures to eliminate or minimise the risk, so far as is reasonably practicable include guarding or shielding the hazard, effective maintenance of plant and providing PPE.

Grain augers and elevators

An essential consideration in the selection of a grain auger is that effective guarding is in place to prevent access to dangerous parts. Where available the guards must be incorporated as an integral part of the grain auger.

Different types of grain will have different flow characteristics so some safety features like mesh size can impede the grain flow. It is important that mesh guards with a suitable aperture size are provided as this will allow a sufficient rate of flow while maintaining an acceptable level of safety when used with an inner guard. Grain augers using mesh with smaller apertures will limit the flow of grain and this information should be provided to the user.

Guarding is often an effective control for augers and screw flightings used to move or transfer granular material. There should always be two levels of guarding—an inner guard permanently fitted over the flighting and a fitted outer guard. The inner guard must be in place when the grain auger is being used. The outer guard must be in position when using a hopper and, so far as is reasonably practicable, for all other uses. Where it is not reasonably practicable to use the outer guard and it is removed, for example when the grain auger is being used in a silo with a narrow discharge chute that the guard will not fit into, ensure people are not directly exposed to the auger flighting during operation. In these situations it may be necessary to provide an alternative outer guard.

Before selecting an auger you should check the following:

- Is the auger suitable for your intended use?
- Will you be able to relocate the auger using existing farm vehicles?
- Are drive belts, pulleys, chains, sprockets and drive shafts fully guarded including guards to prevent contact from behind?
- Do fixed inner guards have bars able to withstand deformation? A maximum spacing of 75 mm is recommended.
- Are the outer guards removable? Mesh with maximum 100 x 100 mm apertures is recommended.
- Does the distance between the inner and outer guards prevent contact with the auger? A minimum of 120 mm is recommended.
- Is the emergency stop control next to the auger inlet?
- Are winches properly guarded to prevent hands being caught between the winch drum and the wire rope?
- Are wire ropes used for raising and lowering the auger fastened using swaged, socketed or spliced eyes and thimbles?
- Does the winch drum have a device to ensure correct winding of the rope?
- Is a jockey wheel provided to aid manoeuvrability?
- Are safety signs warning of risks clearly displayed?
- Are operating instructions provided and housed in a weatherproof receptacle?
- Are the necessary transportation aids provided? Are inspection and maintenance requirements provided?
- Is a safe storage area available?

The auger should only be operated according to the manufacturer's instructions. The auger should not be operated or moved in a manner in which it may come into contact with overhead electric lines. The auger should always be emptied and lowered before moving.

Suitable PPE must be provided to workers using the auger. Hearing protectors should also be worn while the equipment is operating if excessive noise is produced.

Plant that lifts or suspends loads

As the person with management or control of plant you must make sure the plant is specifically designed to lift or suspend the load. If this is not reasonably practicable, you must ensure the plant does not create greater risk than if specifically designed plant was used. If people are lifted or suspended the workbox should be securely attached to the plant, people should remain within the workbox, wear safety harnesses and there should be an escape plan if the plant fails.

Further information including extra requirements when using a crane to lift people, is in the *General guide for cranes*.

Set-up and safe use of elevating work platforms

People operating an EWP are at risk of injury and as the person with management or control of plant you must ensure you manage the risk so far as is reasonably practicable.

Heritage plant

Heritage plant is plant that is intended to be preserved in its current operational form for historical value and not for normal use at a workplace, for example a vintage tractor may be used for display or demonstration purposes only.

Tractors

Tractors are items of plant commonly used in rural workplaces and often cause injuries and deaths, especially in rollover and run over incidents. These deaths occur regardless of the size of the farm, the age or type of tractor and the age or experience of the operator.

ROPS must be fitted to tractors unless an exemption applies. Other safety features which should be included at the design, manufacture and operation stage include:

- falling object protective structures (FOPS)
- guards e.g. for a power take-off (PTO)
- ergonomic operator controls
- safe access platforms
- protection from noise, vibration and sun exposure, and
- other measures for operator health and safety e.g. seat belts.

Tractors can also be fitted with a variety of attachments and implements, with each particular attachment introducing a new set of hazards, even if the tractor itself is set up for safe use. Planning and selecting the correct equipment for the intended task and terrain is an important step in managing risks.

A tractor should not be operated in 'creep-mode' without a driver being seated at the controls unless the tractor has been specifically designed for that purpose and 'creep-mode' can be turned off remotely.

Carrying passengers on mobile plant including tractors should not be done unless the passenger is provided with protection equivalent to that of the operator like a proper passenger seat with restraints and rollover protection.

The operator of the tractor and any passengers should not get off a tractor while it is moving.

If there is a possibility of the tractor colliding with pedestrians or other powered mobile plant, the tractor must have a warning device that will warn persons who may be at risk from the movement of the tractor.

Rollover protective structures

The person with management or control of a tractor at a workplace must make sure a ROPS is securely fitted to a tractor.

A ROPS does not need to be fitted if the tractor is:

- installed in a fixed position in a way which would not permit it to be used as powered mobile plant
- less than 560 kg or more than 15 000 kg in mass, or
- being used for an historical purpose or activity i.e. heritage plant.

A tractor exempt from having a ROPS fitted should not be used at a workplace unless the proposed activities have been assessed for the risks to health and safety and the owner has taken all steps to eliminate or minimise the risks, so far as is reasonably practicable.

A ROPS is designed and constructed to eliminate or minimise the risk of death or injury to the tractor operator if the tractor rolls over. A ROPS will not prevent a rollover but will protect the operator from being crushed if the tractor overturns.

Tractors can overturn anywhere, however there is a greater risk of a tractor overturning in the following situations:

- on uneven ground
- on slight and steep slopes
- at edges of depressions
- near contour banks or water courses
- when towing or pulling light, heavy, stable and unstable loads, and
- when the tractor is travelling at a speed which is not suitable for the terrain.

ROPS should always be used with a seat belt to prevent the operator being thrown into the crush zone if an incident occurs.

A fold-down ROPS with a locking device may be used where a tractor is operating in a place that is too low for the tractor to work with a fixed ROPS, for example inside or close to buildings or near trees (see Figure 2), and if other measures to minimise rollover risks are in place. The ROPS must be returned to the intended upright position as soon as the task for which it was lowered is completed.

Figure 2 Tractor with a fold-down ROPS fitted - note the locking pins (see arrows)

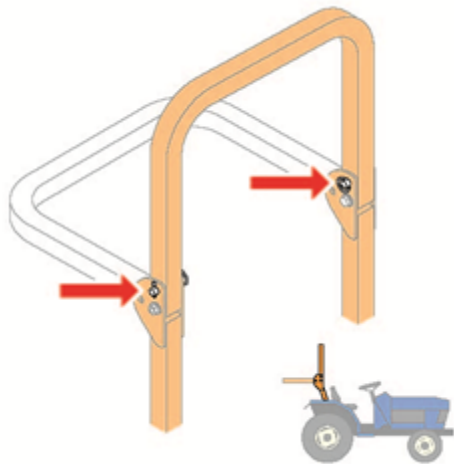

A ROPS has a limited lifespan and should be inspected regularly to identify signs of physical deterioration, for example dents, rust or cracks. The structural integrity of a ROPS can be impaired by continuous impact corrosion and this may be indicated by deformation or cracking of the structure. A ROPS in poor condition should be replaced.

A manufacturer should ensure every ROPS approved under a technical standard is permanently marked with the following readable information:

- the name and address of the manufacturer of the ROPS
- a ROPS identification number
- the date of manufacture
- the make, model or serial number of the tractors the structure is designed to fit, and
- the relevant Australian Standard or other technical standard with which the structure complies.

Falling object protective structures

If a tractor is capable of being used for tree felling or in other situations which create a risk to the operator of falling objects it should be designed so it can be fitted with a FOPS. A FOPS is a system of structural members and sheeting attached to a tractor to provide the operator with protection from falling objects e.g. branches, rocks and hay bales.

A manufacturer should ensure every FOPS approved under a technical standard is permanently marked with the following readable information:

- the name and address of the manufacturer of the FOPS
- a FOPS identification number

- the date of manufacture
- the make, model or serial number of the tractors the structure is designed to fit
- the relevant Australian Standard or other acceptable technical standard with which the structure complies, and
- other relevant information provided by the manufacturer e.g. information about installing, repairing or replacing plant and parts.

Access platforms

A safe access platform should be fitted to prevent an operator or another person from being positioned between the front and rear wheels when accessing the tractor or when working nearby while it is moving (see Figure 3 for an example). This type of design will reduce the risk of a person being pulled under the wheel of the tractor if the person slips, trips, falls or moves into the tractor working zone or the tractor moves unexpectedly. The access platform should be designed to enable operators to use three points of contact as they enter and exit the tractor e.g. two hands and one foot.

Figure 3 Tractor access platform



Power take-off attachments and guards

PTO attachments should not be used unless fitted with suitable guards to prevent entanglement.

The PTO, shaft and universal joints should be inspected regularly for wear. Guards should be maintained and replaced when they are damaged or worn.

A PTO shaft assembly consists of a tractor power output coupling (POC), PTO shaft and implement power input coupling (PIC). All of these components should be guarded. The tractor POC guard is generally known as the master guard and should be permanently attached to the tractor. The implement PIC guard should be permanently attached to the implement. If it is necessary to access behind the POC or PIC for maintenance or cleaning, the guard is a physical barrier which cannot be removed or altered without tools and is secure when the tractor is in use.

The PTO shaft guard should extend into the tractor POC guard area and the implement PIC guard area for the maximum possible distance (see Figure 4 for example). The guard may be a rotating or non-rotating type guard. Non-rotating type guards should be restrained. There should be no nip or catch points where body parts or clothing can be caught. When selecting a guard the supplier should confirm it has been made and tested to the relevant Australian Standard and it is the correct size and length for the drive shaft taking into account the shaft's vertical and horizontal movements when operating.

Figure 4 Tractor PTO guarding

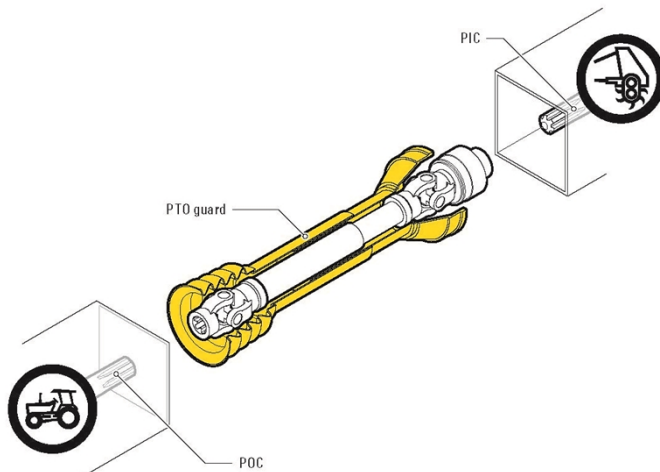

For all PTO guarding:

- Check PTO guards when stationary for wear and damage regularly, for example daily before use. Damaged guards should be replaced before use.
- Where it is necessary to have some form of protection in the PTO, drive line torque limiters, free wheels or clutches should be located at the power input connection (implement end) of the PTO drive shaft.
- Protections designed to cover the PTO at the power output connection should be used.
- The restraining devices used to prevent the rotation of the shaft guard should not be used as a means of supporting the PTO drive shaft or guard when the machine is uncoupled.
- When the machine is not in use support the drive shaft and guard on the cradle provided. If there is no cradle, support the shaft and guards by other means to give equivalent protection against damage.

When working with PTO equipment you should always:

- stop the tractor engine
- ensure controls are in neutral and the handbrake is applied
- remove the engine key
- wait for movement to stop before attempting to clear blockages
- use a tool to clear blockages, and
- disengage the power drive.

Front end loader attachments

FEL attachments should be supplied with a support stand which places the arms at the correct height so the tractor can be driven in or out when connecting or disconnecting the arms. The support stand should be on a firm, level surface capable of supporting the weight of the unhitched FEL attachment.

Before using a tractor and FEL attachment you should complete a risk assessment and consider the operator, machine and environment in which it will operate. When assessing the risks from using a FEL attachment consider:

- whether the operator has relevant skills and knowledge
- the potential for carried objects or loads to roll back or fall on to the operator
- whether the front axle, wheels and tyres of the tractor are capable of handling the weight imposed by the FEL attachment when it is fully loaded
- the lifting capacity of the tractor's hydraulic system
- whether there is sufficient clearance between the tractor's front tyres and the FEL attachment frame to eliminate contact during turns
- the stability of the tractor operating a fully loaded FEL attachment
- whether the selected FEL attachment is suitable to lift the load e.g. round hay bales should not be lifted or carried using the FEL bucket—a purpose-designed bale spike or grab should be used
- the operating conditions related to the density of material to be handled e.g. nature of material and whether wet or dry
- the dimensions of the load to be lifted
- the travelling speed which affects stability on bumps or turns
- the load height during travel
- the ground conditions e.g. direction or angle of slope, evenness and hardness of surface or other environmental conditions, and
- whether the rated operating load of the FEL attachment might be exceeded.

A FEL attachment should not be installed on a tractor unless it is fitted with a ROPS or a cabin incorporating a ROPS. The ROPS should preferably be a four post ROPS or a ROPS forward of the operator to provide a level of protection if an object rolls back from the bucket or lifting mechanism.

Load rollback may also be prevented by using:

- specialised lifting attachments e.g. a bale spike
- a level lift system
- a rollback guard, and
- a lifting height limiting device.

Where there is a risk of objects or material falling on to the operator the ROPS should be fitted with a FOPS.

It is important to check the operating environment to identify visible hazards like rocks, stumps, depressions or unstable ground before using the tractor and FEL attachment.

Quick release hydraulic couplings allow easy attachment and detachment. These should be clearly marked to avoid incorrect connection. Hydraulic pressure should be released before disconnection.

Post drivers

Post drivers are potentially hazardous. You should carefully select a device suitable for the intended use.

The manufacturer's or supplier's instructions on the safe use of the post driver must be followed and these may include:

- limitations on its use
- how to attach and detach the post driver to and from the tractor
- how to store and transport the post driver safely
- safe operating instructions
- a warning about overhead electric lines and underground services including the envelope of the plant
- necessary PPE
- the tractor specifications necessary to operate and transport the post driver safely e.g. mass, width of wheel track, category of linkage
- details of the inspection and maintenance requirements for each item and component and the post driver as a whole including a pre-operational checklist
- how to turn off and remove the key to the post driver when it's not being operated, and
- how to use guards.

If a tractor is being used to power the post driver, the tractor should be compatible with the post driver. There should also be a suitable area to store the post driver where the conditions will not affect its operational capability.

When selecting the most suitable post driver, check that the guard is designed as an integral part of the post driver and the device protects the operator. For example, the hammer should be guarded to a height of 2.4 metres above ground level and at least 300 mm below the bottom of the hammer's drop height. For post drivers designed to drive posts their entire length into the ground guards should be no more than 300 mm above ground level and at least 300 mm from the faces of the hammer.

Extra control measures may be required to protect the operator from impact from particles ejected during the operation like a separate guard at the operator's position or a hammer that encloses the top of the post.

If it is necessary to temporarily remove the guard to carry out the work, check the post driver allows for the hammer speed to be restricted. Other nip, shear and crush points, for example positional controls and hinged guards, should be designed to prevent shearing and crushing.

This may be done by guarding or controlling the speed of movement or operation, for example tilts at a maximum 10 degrees per second and side shift at 100 mm per second.

Post drivers used to replace posts in existing fences should not damage the fence. One option is to have a guard comprising horizontal bars only. In this case the bars should be rigid, for example steel not less than 25 mm diameter. They should be spaced vertically at a safe distance from the outer face or point and sides of the hammer, for example no more than 150 mm apart and a minimum of 300 mm from the hammer.

Check drive belts, pulleys, chains, sprockets and drive shafts are fully guarded including 'back guarding' to prevent contact from behind. Chains and sprockets should be fully enclosed for their whole length. For winch-activated post drivers guards should be provided to prevent physical contact with the nip points between the ropes and sheaves. Ropes should be prevented from becoming displaced from sheaves.

Guards should be secured by an interlocking device which will prevent the post driver operating and will automatically stop it if the guards are removed or opened. Where this is not possible, guards should not be able to be removed without the use of tools. The drop speed of the hammer should be restricted while the guard is opened to limit the drop speed to 100 mm per second.

For guards comprising fixed horizontal bars, a vertical gap may be incorporated in the front of the guard to assist positioning of the post and enable the post driver to be withdrawn following the operation. In this instance the gap should be no more than 250 mm wide. Also consider using a guard at the operator's position to protect them from particles that may be ejected from the post during the driving operation and to prevent the operator from reaching the post when standing in the operator's position. This type of guarding should never be used for automatic post drivers.

Guards are not an effective control measure if moving or dangerous parts are still accessible whilst the post driver is in operation.

Farm vehicles

Incidents involving farm vehicles are a major cause of injury and death in the rural industry. Quad bikes are a leading cause of injury and death on Australian farms.

Vehicle related incidents involve rollovers, vehicles running over people and incidents caused by unsafe maintenance activities. A person can fall from a truck, utility or tractor while riding in or on the vehicle unrestrained, resulting in serious injury or death.

Road transport rules require that farm vehicles must be registered for use on public roads. Other legislation requires they meet relevant safety standards to be sold in Australia including being fitted with safety features like seatbelts.

Selecting a vehicle

Identify your needs and relevant operator safety issues

Before selecting a farm vehicle, you should identify your needs and relevant operator safety issues. You should select a farm vehicle that is 'fit for purpose' based on its suitability for the task, work environment, operating requirements and operator training needed.

When making a list of your needs, some things to consider include:

- **Tasks** – What tasks will the vehicle be used for? What does it need to do?
- **Conditions** – What conditions will the vehicle be used in? Will they be rocky, uneven, muddy or sandy?
- **Operator** – Who will be operating the vehicle? What training do they have or will they need? What age and size are they? What are their physical limitations?
- **Training** – Do you have the necessary skills and expertise to train the operators or will you need to seek external trainers?
- **Passengers** – Will the vehicle need to carry passengers? How many people will it need to carry?
- **Loads** – What will be carried on the vehicle? How large is the load? How much will it weigh?
- **Towing** – Will the vehicle be used to tow trailers or other attachments? If so, what size will the attachment be and how will it affect vehicle stability?
- **Safety** – Which vehicle provides the operator and any passengers with the greatest level of safety for each task?
- **PPE** – What PPE will you need to provide? E.g. helmets, gloves and boots.
- **Maintenance** – Will you have the capacity to maintain the vehicle you select in accordance with the manufacturer's specifications?

Compare vehicle options to your needs

Once you have identified your needs, you should compare suitable vehicle options against them. Information to help you choose the best vehicle for your needs can be found from the internet, trade publications like magazines, and by talking to suppliers and current owners or operators of vehicles.

Some choices include utilities, tractors, trucks, motorcycles, light off-road utility vehicles (sometimes called SSVs), quad bikes and other powered mobile plant for farm use. As a PCBU, it is your responsibility to be aware of the risks associated with the equipment you use.

The safety aspects of using trucks and utilities that have an enclosed cabin and seatbelts should not be reduced by modifying the vehicle, for example where doors are removed for regular access or cabins are modified, or not wearing a seat belt.

The improper selection of plant for the task can create significant hazards like plant instability or operators being crushed due to lack of ROPS and FOPS.

Quad bikes

Quad bikes, sometimes referred to as all-terrain vehicles (ATVs), are four wheeled vehicles with a saddle seat. They are not safe for use in all terrains. Quad bikes are a major cause of death and serious injury each year on farms with many incidents associated with sideways, backward and forward rollover. Quad bikes may pose an increased risk to the user over those known to exist for other powered mobile plant including tractors, four-wheel-drive vehicles or SSVs.

Where possible, quad bike hazards should be eliminated or removed from the workplace. You should carefully consider the safest and most appropriate vehicle for your purposes, in many cases this will not be a quad bike.

Quad bikes can roll over for a variety of reasons, even when travelling slowly. The risk of rollover is increased if the quad bike:

- is traversing slopes
- is travelling at high speed
- is towing an implement
- is travelling over steep, rocky or uneven ground
- is carrying a heavy or unstable load e.g. spray tanks with liquids for spraying weeds, and
- has tyres under-inflated or unevenly inflated.

Under these circumstances consideration should be given to an alternative vehicle to a quad bike to minimise the risk of injury due to rollover. SSVs may be more suitable for use in rural workplaces because the operator remains seated and they generally have ROPS and restraints like seat belts to protect operators and passengers if there is a rollover (see Figure 5). Two wheeled motorcycles may also be suitable for some specific tasks given their mobility and light weight.

Figure 5: Typical light utility (SSV). Consider whether an SSV would be a safer alternative for your workplace.



Where practicable, your workplace risk assessment may lead you to implement alternative work methods to minimise risk. For example livestock grazing or controlled burning may be effective in weed management rather than spraying using a farm vehicle.

Selecting a quad bike

If a quad bike is the most suitable vehicle for your needs you should discuss your options with the supplier. You can expect the supplier to provide all the necessary information, including:

- vehicle specifications and selection
- training requirements
- operator protective devices they supply
- other available risk controls e.g. remote personal locator beacon, and
- PPE they supply.

Some other relevant considerations when selecting a quad bike include:

- **Size and throttle power** – A key safety consideration for larger and more powerful quad bikes, especially for inexperienced riders, is being able to comfortably manage the throttle action when starting off and changing gears while on the move. It is important that the quad bike used is suitable for the work task, for example a smaller quad bike may be more suitable when driving than a larger or more powerful model.
- **Stability** – As quad bikes have a higher centre of gravity and narrow track width, they are not as stable as other vehicles. Remember the carrying capacity of a quad bike will be reduced by your own weight, the weight of attachments and the load to be carried on those attachments. Allowing working dogs to ride on the quad bike will add an additional load that could affect stability when critical manoeuvres are being performed.
- **Passengers** – Most quad bikes are designed for one rider. Never carry passengers on a single person quad bike.
- **Operator** – The operator must be able to safely operate the vehicle. Quad bikes require an active riding technique that may be physically demanding over long periods, particularly for older riders.
- **Loads and towing** – Check the vehicle manufacturer's specifications for weight and towing. Towing attachments or carrying loads on the front or rear racks of a quad bike is convenient but will affect stability and handling. Liquid loads, such as spray tanks, add considerable weight and are particularly unstable as contents shift when cornering or traversing slopes. If the tank does not contain baffles, the weight of the liquid is free to move into positions that may further impair stability. Always attach loads securely and at the lowest possible height.
- **Tools** – Unrestrained tools or implements carried on a quad bike can be ejected with some force if the bike meets with a hazard such as rough terrain, resulting in personal injury to the rider and possibly causing them to lose control of the vehicle.
- **Conditions** – Rocky, steep, uneven, sandy or muddy terrain will greatly increase the risk of quad bike rollover.
- **Wheelbase** – Check whether the wheelbase is so short that it could cause the vehicle to pitch greatly under heavy braking or on inclines.
- **Length of suspension travel** – check whether there is enough suspension travel for the wheels to remain on the ground over rough terrain.
- **Tyre pressure** – Tyre pressure is very important to maintain quad bike stability. Check whether the tyre pressure is suitable for the terrain and conditions.

Conduct a risk assessment

A risk assessment can help you choose the right risk controls. You should consider more reliable and effective risk controls such as substitution and isolation first, before applying administrative controls such as training and PPE.

A combination of control measures may be appropriate to provide the greatest reduction in risk, for example, vehicle selection, fitting operator protective devices, following the manufacturer's instructions, safe use of attachments, safe work procedures, instruction, training and PPE.

Isolate quad bike related hazards

If you have chosen a quad bike for your workplace, you should isolate the quad bike related hazards. This may include physically blocking off access to particularly hazardous areas such as unstable ground or steep slopes and removing keys from the quad bike when it is not in use so unauthorised people cannot ride it.

Crush protection devices

If quad bike related hazards cannot be eliminated or isolated from the workplace, they should be minimised through engineering controls.

The unique design characteristics of quad bikes generally prevent the fitting of traditional operator protective devices like ROPS and seat belts.

However, operator protective devices including crush protection devices are available and may protect the rider in the event of a rollover (see Figure 6). These devices should only be fitted where a risk assessment shows the device will reduce the risk, for example they may not be suitable for use in heavily wooded areas.

Figure 6: Quad bikes can be fitted with a crush protection device which may lower the risk of injury in the event of vehicle rollover.



Safe operation

Administrative controls to improve operators' safety should be used to further reduce the hazards of quad bikes in the workplace.

Training and operation

Before a quad bike is used in your workplace you must provide anyone who will use it with the information, training, instruction or supervision necessary to protect them and others from associated risks.

No operator should use a quad bike for farm work without first undertaking training.

Quad bike training helps operators understand the risks associated with using quad bikes and attached equipment and can help with active riding techniques.

Often a combination of both general and task specific training is required to ensure that a person is competent and can safely operate a quad bike. The training you provide may be from a supplier, manufacturer or industry training provider.

It is important riders are provided with, understand and implement the manufacturer's operating instructions for the type of quad bike being used. The manufacturer's instructions should always be followed.

Children and quad bikes

One in five fatal quad bike incidents involve children.

You have a duty of care to ensure other people in your workplace are not exposed to health and safety risks, including children.

You should never let children under the age of 16 operate adult sized quad bikes and SSVs.

You should never let children between the ages of 6 and 16 operate a youth sized quad bike or SSV that is not specified to be appropriate according to the manufacturer's age recommendation for that particular vehicle.

If children are to operate a youth sized quad bike that is within the manufacturer's specifications for their age, they should be provided with the same comprehensive training and instruction as adult riders.

You should never carry children as passengers on single rider quad bikes. Carrying children or other passengers significantly increases the risk of rollover and adversely affects quad bike stability.

Communication

If you will be working remotely and alone, you should tell someone where you will be working and have a communication plan with regular check-in times.

Farm safety plan

Conduct a risk assessment and produce a set of rules for quad bike operation on your property. These rules should be based on the manufacturer's specifications and safety warnings. At a minimum, your farm safety plan should include:

- any no-go areas for a quad bike on the property
- what speed the quad bike is to be ridden
- what conditions the quad cannot be used in
- information prohibiting carrying passengers, and
- any attachments that can be safely used.

Maintenance

Quad bikes should be well maintained. Check the manufacturer's instructions for maintenance information.

In maintaining a quad bike consider the following:

- Tyre pressure should be correct and in accordance with manufacturer's specifications.
- Safety equipment should be in place and well maintained.
- Operator manuals should be readily available for each machine.
- The keys of machinery should be removed and stored away from unauthorised users (e.g. children), when not in use.
- Routine services and maintenance should be carried out on machinery and records kept.
- Lights and reflectors should be clean and functional.
- The power should be turned off and isolated before adjusting, unclogging and servicing a power-driven machine.
- Exhaust systems should be regularly checked to ensure they are functioning properly.

Personal protective equipment

Always wear an appropriate and properly fitting helmet, regardless of the operating environment. When riding on a public road you must wear a helmet that complies with AS/NZS 1698:2006: *Protective helmets for vehicle users*.

Other PPE like face shields, goggles, boots or shoes, gloves and suitable clothing should also be worn.

In open terrain operation or in continuous low speed operation, less protective or alternate clothing may be chosen. A risk assessment should be conducted when conditions change or control measures are altered e.g. using alternate clothing. You should also be aware of sun exposure and the risk of dehydration when selecting PPE.

Plant not in use

Parking and shutting down plant

Plant must be parked, shut down and left in a safe state to prevent accidental or unauthorised use. If plant is found to be unsafe for normal use it should be clearly identified as being out-of-service and should not be operated except by a competent person to rectify the fault. A competent person is a person who has acquired through training, qualification or experience the knowledge and skills to carry out the task.

Storing plant

Plant that is not intended to be used should be immobilised and safely stored:

- so it does not hinder, obstruct or interfere with the operation of other plant
- in a stable position so it cannot fall
- to prevent unintentional activation e.g. by someone leaning on the controls
- so combustible liquids cannot be released accidentally e.g. fuel or oil, and
- to prevent deterioration to the extent it later becomes unsafe to use.

Maintenance, inspection and repair

A preventative maintenance, inspection and repair program for plant helps keep the plant in a safe condition. Maintenance, inspection and repair must be carried out by a competent person and should be based on the manufacturer's instructions. If it is not reasonably practicable to comply with the manufacturer's instructions the work should be done according to a competent person's instructions.

When carrying out maintenance, inspection and repair, energy sources likely to injure someone should be removed or isolated to eliminate or minimise risks like electrocution or crushing. This includes *stored* energy, like the energy created by hydraulic components under pressure, or *potential* energy, like an elevated forklift carriage that could move under gravity.

Plant should be regularly cleaned to detect loose, worn or defective parts and to prevent defects that might lead to hazards like oil or fuel leaks and fires.

Maintenance and inspection records

Records of maintenance, inspections, alterations or tests carried out on plant should be kept at or near the workplace for as long as the plant is in the workplace.

Records should include:

- information that identifies the plant
- the date of inspection, service and repair
- operating hours meter readings — where a meter is fitted
- detailed report of repair work carried out
- name, qualifications and competency of the person who carried out the work, and
- details of alterations made to the plant.

Altering plant

A simple modification may not alter the design of the plant or the way it operates. However a substantial modification can alter the design characteristics of the plant and affect its safety. If the plant is registered, you must notify the regulator of a design alteration within 14 days. For example, welding a bracket on to a boiler may alter the integrity of the plant by reducing the structural strength but welding an extra cover to a metal guard is unlikely to reduce the capacity of the guard to perform its task. Other circumstances where the regulator must be notified include where fixed registrable plant like a boiler is relocated, if the registration holder's name changes or if the registration holder no longer has management or control of the plant.

A person who modifies plant used at a rural workplace has the same obligation as a designer and a manufacturer under the WHS Regulations.

If you need to modify plant you have several options including:

- carrying out the work yourself if you are a competent person
- sending it to the manufacturer or supplier to be modified, or
- sending it to a local engineering workshop that has the expertise to carry out the work safely.

If you carry out modifications that introduce new risks or hazards you should:

- Gather information preferably from the manufacturer or a relevant technical standard about the plant. This will help you to include safety measures when making the modification.
- Carry out an assessment of the change using the information gathered to make sure the safety measures minimise the risks so far as is reasonably practicable. You should implement further control measures for risks highlighted in the assessment.

If you are unsure of your assessment get independent advice. You should only modify plant in ways recommended by the manufacturer or other documented procedures.

Modification of safety measures already located on the plant should not be done. For example, welding brackets on to a ROPS or drilling holes may affect structural integrity which will dramatically reduce the protective ability of the structure.

You must, so far as is reasonably practicable, include information on plant modifications and the implemented control measures when training workers or other people who will use the plant.

NT WorkSafe

Work Health and Safety

Toll-free 1800 019 115

Email ntworksafe@nt.gov.au

Fax 08 8999 5141

Workers Rehabilitation and Compensation

Toll-free 1800 250 713